



Operating Instructions

Ultra-Low Temperature Freezer

MDF-C2156VAN

MDF-C2156VANC Series

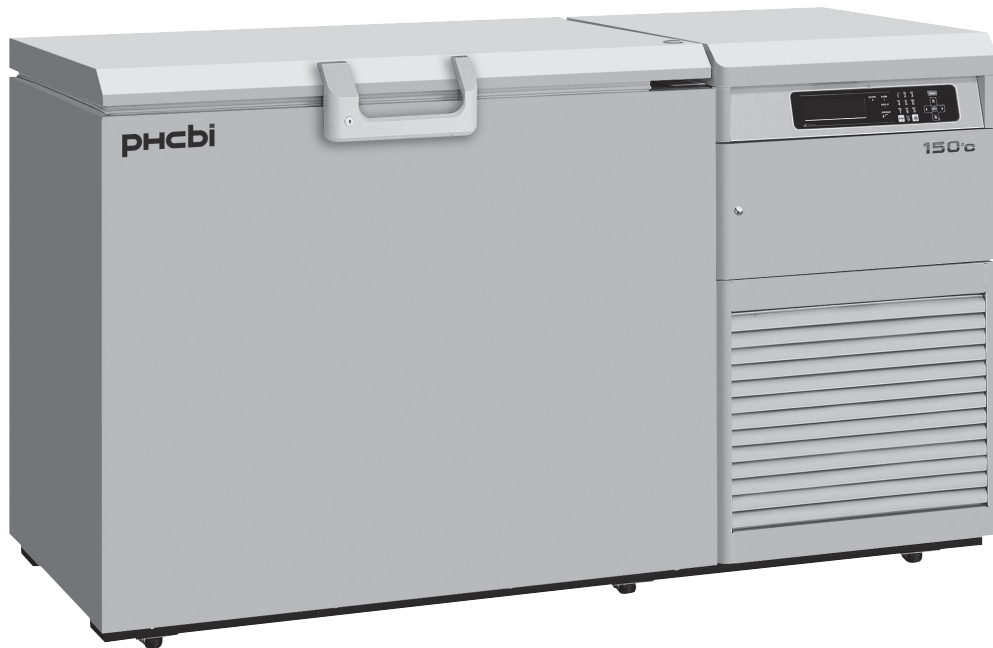

MDF-C2156VAN

Please read the operating instructions carefully before using this product, and keep the operating instructions for future use.

See page 40 for all model numbers.

CONTENTS

INTRODUCTION	P. 2
PRECAUTIONS FOR SAFE OPERATION	P. 3
ENVIRONMENTAL CONDITIONS	P. 7
FREEZER COMPONENTS	P. 8
Control panel	P. 11
INSTALLATION SITE	P. 12
INSTALLATION	P. 13
START-UP OF UNIT	P. 14
Operation after power failure	P. 14
BASIC SCREEN OF CONTROL PANEL	P. 15
FUNCTION OF CONTROL PANEL	P. 15
RUNNING OPERATION (MENU/Set)	P. 16
Key lock function	P. 17
Key lock release function	P. 17
VARIOUS SETTING (MENU/Log)	P. 18
Display of log (Log)	P. 18
PC setting	P. 19
VARIOUS SETTING (MENU/Tools)	P. 20
Initialization (Tools/ Default Setting)	P. 20
Setting of date, time, log interval (Tools/Date Time)	P. 21
Setting of key lock password (Tools/Key lock PW Setting)	P. 22
ALALRM BUZZER	P. 22
MONITOR OF FREEZER STATUS	P. 23
ALARMS & SAFETY FUNCTIONS	P. 23
REMOTE ALARM TERMINAL	P. 25
ANALOG OUTPUT TERMINAL	P. 25
BACKUP COOLING KIT	P. 25
ROUTINE MAINTENANCE	P. 27
Cleaning of cabinet	P. 27
Cleaning of condenser filter	P. 27
Defrosting of inside wall	P. 28
REPLACEMENT OF BATTERY	P. 29
TROUBLESHOOTING	P. 30
DISPOSAL OF UNIT	P. 31
Recycle of battery	P. 31
TEMPERATURE RECORDER (OPTION)	P. 36
MOUNTING OF INTERFACE BOARD (OPTION)	P. 38
SPECIFICATIONS	P. 39
PERFORMANCE	P. 40
SAFETY CHECK SHEET	P. 41

INTRODUCTION

- Read the operating instructions carefully before using the product and follow the instructions for safe operation.
- PHC Corporation takes no responsibility for safety if the product is not used as intended or is used with any procedures other than those given in the operating instructions.
- Keep the operating instructions in a suitable place so that they can be referred to as necessary.
- The operating instructions are subject to change without notice for improvement of performance or function.
- Contact our sales representative or agent if any page of the operating instructions is lost or the page order is incorrect, or if the instructions are unclear or inaccurate.
- No part of the operating instructions may be reproduced in any form without the express written permission of PHC Corporation.

IMPORTANT NOTICE

PHC Corporation guarantees this product under certain warranty conditions. However, please note that PHC Corporation shall not be responsible for any loss or damage to the contents of the product.

PRECAUTIONS FOR SAFE OPERATION

It is imperative that the user complies with the operating instructions as it contains important safety advice.

Items and procedures are described so that you can use this unit correctly and safely. If the precautions advised are followed, this will prevent possible injury to the user and any other person.

Precautions are illustrated in the following way:



WARNING

Failure to observe WARNING signs could result in a hazard to personnel possibly resulting in serious injury or death.

CAUTION

Failure to observe CAUTION signs could result in injury to personnel and damage to the unit and associated property.

Symbol shows;

-  This symbol means caution.
-  This symbol means an action is prohibited.
-  This symbol means an instruction must be followed.

Be sure to keep the operating instructions in a place accessible to users of this unit.

< Label on the unit >



This mark is labeled on the cover in which the electrical components of high voltage are enclosed to prevent the electric shock.

The cover should be removed by a qualified engineer or service personnel only.

WARNING











As with any equipment that uses N₂ gas, there is a likelihood of oxygen depletion in the vicinity of the equipment. It is important that you assess the work site to ensure there is suitable and sufficient ventilation. If restricted ventilation is suspected, then other methods of ensuring a safe environment must be considered. These may include atmosphere monitoring and warning devices.

For the State of California, USA Only:

This product contains a CR Coin Cell Lithium Battery which contains Perchlorate Material – special handling may apply. See www.dtsc.ca.gov/hazardouswaste/perchlorate.















PRECAUTIONS FOR SAFE OPERATION

WARNING

-  **Do not use the unit outdoors.** Current leakage or electric shock may result if the unit is exposed to rain water.
-  **Only qualified engineers or service personnel should install the unit.** The installation by unqualified personnel may cause electric shock or fire.
-  **Install the unit on a sturdy floor and take an adequate precaution to prevent the unit from turning over.** If the floor is not strong enough or the installation site is not adequate, this may result in injury from the unit falling or tipping over.
-  **Never install the unit in a humid place or a place where it is likely to be splashed by water.** Deterioration of the insulation may result which could cause current leakage or electric shock.
-  **Never install the unit in a flammable or volatile location.** This may cause explosion or fire.
-  **Never install the unit where acid or corrosive gases are present** as current leakage or electric shock may result due to corrosion.
-  **Always ground (earth) the unit to prevent electric shock.** If the power supply outlet is not grounded, it will be necessary to install a ground by qualified engineers.
-  **Never ground the unit through a gas pipe, water main, telephone line or lightning rod.** Such grounding may cause electric shock in the case of an incomplete circuit.
-  **Connect the unit to a power source as indicated on the rating label attached to the unit.** Use of any other voltage or frequency other than that on the rating label may cause fire or electric shock.
-  **Never store volatile or flammable substances** in this unit if the cylinder cannot be sealed. These may cause explosion or fire.
-  **Do not insert metal objects such as a pin or a wire into any vent, gap or any outlet on the unit.** This may cause electric shock or injury by accidental contact with moving parts.
-  **Use this unit in safe area when treating the poison, harmful or radiate articles.** Improper use may cause bad effect on your health or environment.
-  **Turn off the power switch (if provided) and disconnect the power supply to the unit prior to any repair or maintenance** of the unit in order to prevent electric shock or injury.
-  **Do not touch any electrical parts (such as power supply plug) or operate switches with a wet hand.** This may cause electric shock.







PRECAUTIONS FOR SAFE OPERATION

WARNING

-  **Ensure you do not inhale or consume medication or aerosols** from around the unit at the time of maintenance. These may be harmful to your health.
-  **Never splash water directly onto the unit** as this may cause electric shock or short circuit.
-  **Never put cylinders with liquid on the unit** as this may cause electric shock or short circuit when the liquid is spilled.
-  **Never bind, process, or step on the power supply cord, or never damage or break the power supply plug.** A broken supply cord or plug may cause fire or electric shock.
-  **Do not use the power supply cord if its power supply plug is loose.** Such power supply cord may cause fire or electric shock.
-  **Never disassemble, repair, or modify the unit yourself.** Any such work carried out by an unauthorized person may result in fire, or electric shock or injury due to a malfunction.
-  **Disconnect the power supply plug if there is something wrong with the unit.** Continued abnormal operation may cause electric shock or fire.
-  **When removing the power supply plug from the power supply outlet, grip the power supply plug, not the cord.** Pulling the cord may result in electric shock or fire by short circuit.
-  **Disconnect the power supply plug** before moving the unit. Take care not to damage the power supply cord. A damaged cord may cause electric shock or fire.
-  **Disconnect the power supply plug when the unit is not used for long periods.** Keeping the connection may cause electric shock, current leakage, or fire due to the deterioration of insulation.
-  If the unit is to be stored unused in an unsupervised area for an extended period, **ensure that children do not have access and that doors cannot be closed completely.**
-  **The disposal of the unit should be accomplished by appropriate personnel.** Remove doors to prevent accidents such as suffocation.
-  **Do not put the packing plastic bag within reach of children** as suffocation may result.
-  **Connect power supply cord of the product to its own dedicated outlet.** Failure to observe this caution may result in ignition or malfunctioning.
-  **Do not position this unit and the other unit so that it is difficult to operate the disconnection of the power supply plug.** Failure to disconnect the power supply plug may cause fire if there is something wrong with the unit.

PRECAUTIONS FOR SAFE OPERATION

CAUTION

-  This unit must be plugged into a dedicated circuit protected by branch circuit breaker.
-  Use a dedicated power source as indicated on the rating label attached to the unit. A multiple-tap may cause fire resulting from abnormal heating.
-  **Never store corrosive substances such as acid or alkali** in this unit if the cylinder cannot be sealed. These may cause corrosion of inner components or electric parts.
-  **Check the setting when starting up of operation after power failure or turning off of power switch.** The stored items may be damaged due to the change of setting.
-  **Be careful not to tip over the unit** during movement to prevent damage or injury.
-  **Prepare a safety check sheet** when you request any repair or maintenance for the safety of service personnel.

ENVIRONMENTAL CONDITIONS

This equipment is designed to be safe at least under the following conditions (based on the IEC 61010-1):

- Indoor use;
- Altitude up to 2000 m;
- Ambient temperature 5 °C to 40 °C;
- Maximum relative humidity 80 % for temperature up to 31 °C decreasing linearly to 50 % relative humidity at 40 °C;
- Mains supply voltage fluctuations up to ± 10 % of the nominal voltage;
- Transient overvoltages up to the levels of OVERVOLTAGE CATEGORY II;
- Temporary OVERVOLTAGES occurring on the mains supply;
- Applicable pollution degree of the intended environment (POLLUTION DEGREE 2 in most cases).

FREEZER COMPONENTS

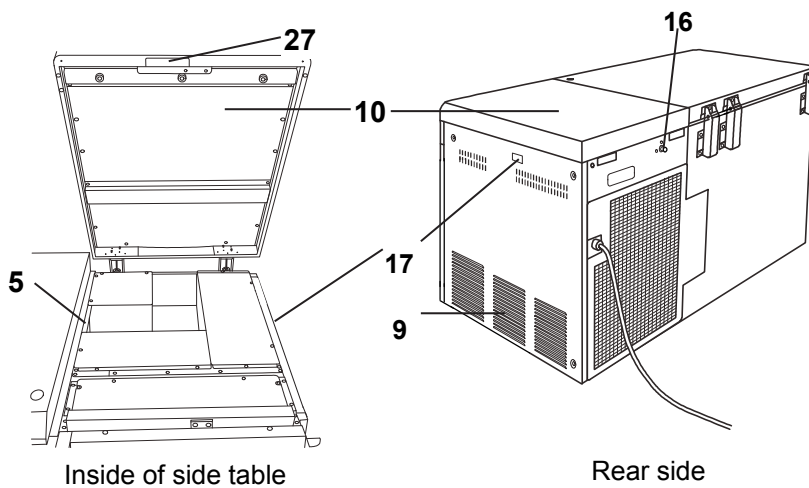
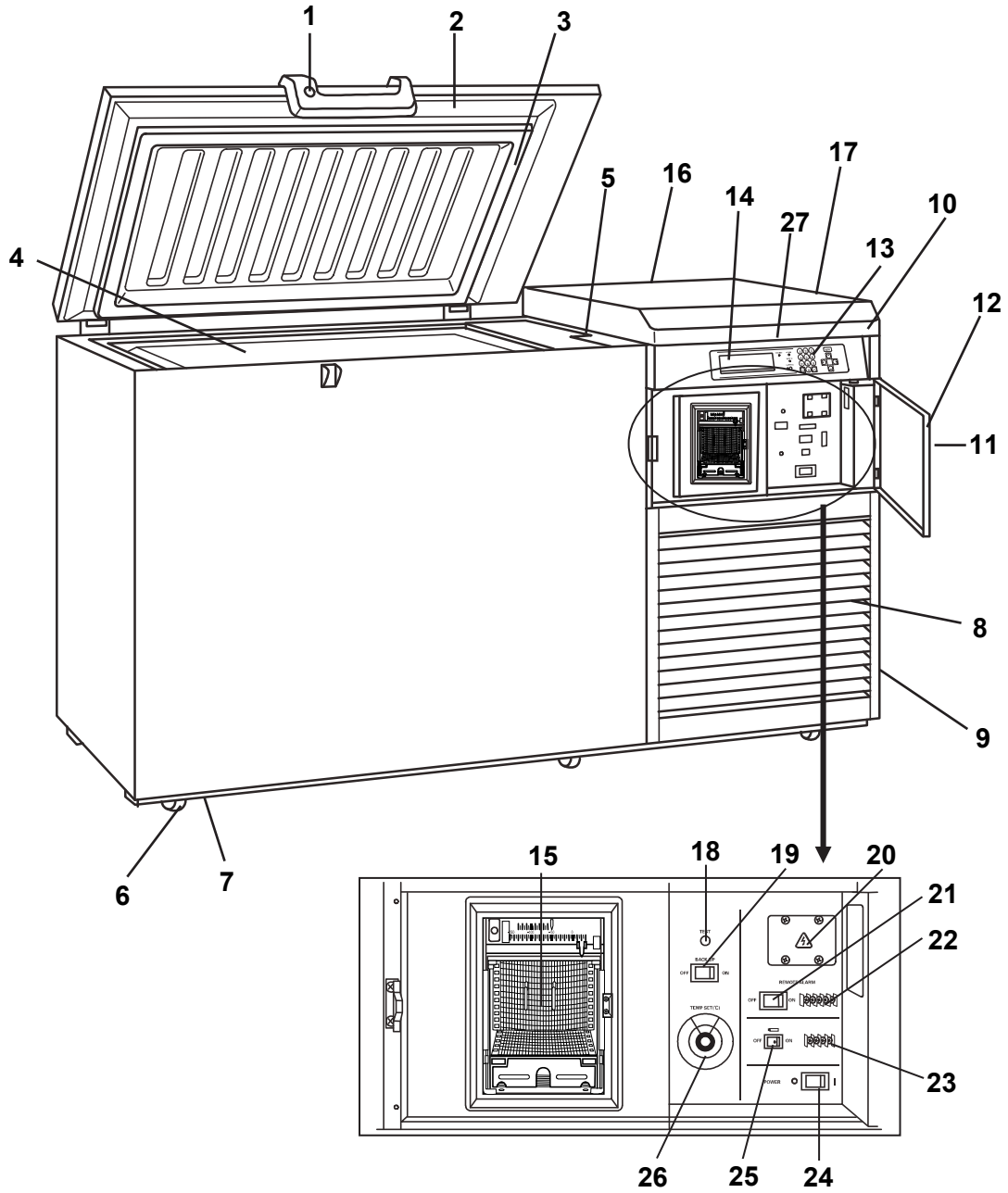

FREEZER COMPONENTS

1. **Lock:** Turn clockwise to 180° with a key and the door is securely locked.
2. **Door:** Hinged type. The door can be opened in any angle on the way to full open.
3. **Magnetic door gasket:** Seals the door and prevents leakage of cold air.
4. **Inner lid:** Serves as a means of reducing cold air leakage when the door is open.
5. **Access port:** Serves a means of leading the measuring cable from the chamber to the outside.
6. **Caster:** 6 casters are provided. They make the moving of the unit easier.
7. **Leveling foot:** Serves to adjust the height and to settle the frame.
8. **Grille:** Acts as an inlet for air to cool the motor. Be careful not to block this. By pulling down this grille, you can clean a clogged condenser filter. See page 27 for the details.
9. **Exhaust air vent:** Be careful not to block this.
10. **Side table:** The side table can be opened. There are access port and remote alarm cable output port in the inside.
11. **Panel door lock:** To lock the control cover to avoid the setting by accidental contact.
12. **Panel door:** There is a controller such as a power switch inside the panel door.
13. **Control panel:** Refer to page 11.
14. **Digital temperature indicator:** This indicator shows the present temperature or setting temperature.
15. **Temperature recorder (OPTION):** Refer to page 38.
16. **Backup cooling kit joint:** It is positioned at rear of the unit. Serves to connect with the pipelines from the cylinder (liquid N₂) at the top left of the rear frame. Refer to page 26 “Backup cooling kit”
17. **Remote alarm cable output port**
18. **Backup test switch (TEST):** Examine the functions of the backup cooling kit. This switch allows liquid N₂ to spout under any circumstances. Handle it according to page 26 “Backup cooling kit”.
19. **Backup switch (BACK UP):** Switch on for operation of the backup cooling kit and switch off for stopping. Handle this switch according to page 26 “Backup cooling kit”.
20. **Communication box cover:** Refer to “Mounting of interface board (OPTION)” on page 40 for usage.

FREEZER COMPONENTS

21. Remote alarm switch (REMOTE ALARM): This switch is for remote alarm. Turn on this switch to enable the remote alarm (function).

22. Remote alarm terminal (MAX DC 30 V 2 A)

23. Analog output terminal (ANALOG VOLTAGE)

24. Power switch (POWER): Power switch of the freezer.

25. Battery switch: It is the switch of the battery for the power failure alarm. Turn it on usually. Turn it off when you do not drive the freezer for a long time. (More than 1 month)

26. Temperature control knob (TEMP. SET(°C)): It is the knob which adjusts operation temperature of the backup cooling kit.

27. Side table handle: There is a lever at the center of the front. When it is pulled to the front, the side table is open.

FREEZER COMPONENTS

Control panel

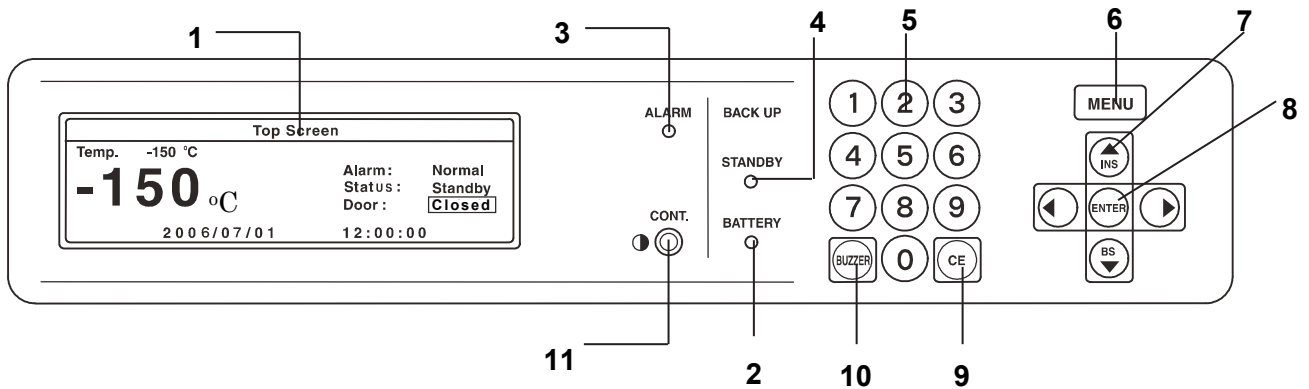

1. LCD panel

2. Battery check lamp (BATTERY): This lamp lights when the battery capacity decreases at the power failure. Batteries are expendable supplies. Replace batteries every three years. For the replacement, contact our sales representative or agent.

3. Alarm lamp (ALARM): This lamp flashes when the unit is in alarm condition.

4. Backup lamp (STANDBY): This lamp lights when the backup switch is on. (This doesn't show backup cooling kit is activated.)

5. Figure input key: User for operation setting.

6. Menu button (MENU): To open the menu window.

7. Shift key (Upward, downward, rightward, leftward): To move the cursor on the LCD panel.

8. Enter key (ENTER): To determine the selection of menu.

9. Clear key (CE): To clear the input value during setting.

10. Alarm buzzer stop key (BUZZER):

- Buzzer stop : Refer to page 22 for the details.

- Alarm test : Refer to page 15 for the details.

- Chamber temperature display : The chamber temperature is displayed by pressing this key during power failure.

11. LCD contrast adjusting knob (CONT.): To adjust the contrast of LCD panel.

INSTALLATION SITE

To operate this unit properly and to obtain maximum performance, install the unit in a location with the following conditions:

■ **A location not subjected to direct sunlight**

Do not install the unit under direct sunlight. Installation in a location subjected to direct sunlight cannot obtain the intended performance.

■ **A location with adequate ventilation**

Leave at least 10 cm around the unit for ventilation. Poor ventilation will result in a reduction of the performance and consequently the failure.

■ **A location away from heat generating sources**

Avoid installing the unit near heat-emitting appliances such as a heater or a boiler etc. Heat can decrease the intended performance of the unit.

■ **A location with little temperature change**

Install the unit under stable ambient temperature. The allowable ambient temperature is between 5 °C and 30 °C.

■ **A location with a sturdy and level floor**

Always install the unit on a sturdy and level floor. The uneven floor or tilted installation may cause failure or injury. Install the unit in stable condition to avoid the vibration or noise. Unstable condition may cause vibration or noise.

 **WARNING**

Install the unit on a sturdy floor. If the floor is not strong enough or the installation site is not adequate, this may result in injury from the unit falling or tipping over.

Select a level and sturdy floor for installation. This precaution will prevent the unit from tipping. Improper installation may result in water spillage or injury from the unit tipping over.

■ **A location not prone to high humidity**

Install the unit in the ambient of 80 %R.H. or less humidity. Installation under high humidity may cause current leakage or electric shock.

 **WARNING**

Do not use the unit outdoors. Current leakage or electric shock may result if the unit is exposed to rain water.

Never install the unit in a humid place or a place where it is likely to be splashed by water. Deterioration of the insulation may result which could cause current leakage or electric shock.

■ **A location without flammable or corrosive gas**

Never install the unit in a location where it will be exposed to flammable or corrosive gas. This may cause explosion or fire or may result in the current leakage or electric shock by the corrosion of the electrical components.

■ **A location without the possibility of anything fall**

Avoid installing the unit in the location where anything can fall down onto the unit. This may cause the breakdown or failure of the unit.

INSTALLATION

1. Removing the packaging materials and tapes

Remove all transportation packaging materials and tapes. Open the doors and ventilate the unit. If the outside panels are dirty, clean them with a diluted neutral dishwashing detergent. (Undiluted detergent can damage the plastic components. For the dilution, refer to the instruction of the detergent.) After the cleaning with the diluted detergent, always wipe it off with a wet cloth. Then wipe off the panels with a dry cloth.

Note:

Remove the cable tie banding the power supply cord. Prolonged banding may cause the corrosion of the cord coating.

2. Adjusting the leveling foot

Stretch the leveling feet by rotating them to contact them to the floor. Ensure the unit is installed horizontally.

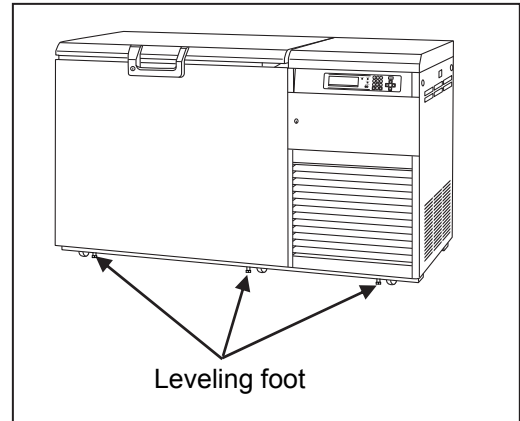

3. Fixing the unit

Two fixtures are attached to the rear of the frame. Fix the frame to the wall with these fixtures and rope or chain.

4. Ground (earth)

The ground (earth) is for preventing the electric shock in the case of unexpected deterioration of the electrical insulation. Always ground the unit at the time of installation.

⚠️ WARNING

Use a power supply outlet with ground (earth) to prevent electric shock. If the power supply outlet is not grounded, it is necessary to install a ground by qualified engineers.

Never ground the unit through a gas pipe, water main, telephone line or lightning rod. Such grounding may cause electric shock in the case of an incomplete circuit.

START-UP OF UNIT

Use the following procedure to start trial operation or actual operation of the unit.

1. Confirm that all switches (power switch, battery switch, remote alarm switch and backup switch) are off.
2. Set liquid N₂ cylinder.
3. Put the inner lid, close the door, and connect a power supply cord to the power supply outlet.
4. Turn on the power switch. The chamber temperature is indicated.
5. Set up the temperature with the temperature control knob when using a backup cooling kit.
6. Turn on the battery switch, remote alarm switch and backup switch.
7. Push the alarm buzzer stop key (BUZZER) for about 5 seconds, and confirm the flashing of the alarm lamp and a buzzer sound. When it is pushed again, an alarm test movement is finished.
8. Push the backup test switch, and confirm that liquid N₂ flows into the freezer chamber.
9. Put the sample to cryopreserve into the freezer chamber. Turn off the remote alarm switch and the backup switch when temperature of the sample is high. Then, turn on these switches under the condition that a sample is refrigerated again.

Operation after power failure

The set value is memorized by nonvolatile memory. Accordingly, the freezer resumes the operation with setting before power failure. During the power failure, the clock function is operating.

- When this product operates at the first start-up or after no use for long period, the built-in battery capacity may be lowered or completely zero because of discharge of the battery. After installation the product, the freezer should operate for more than three days (72 hours) to charge the battery.

BASIC SCREEN OF CONTROL PANEL

When the power switch is turned on, the basic screen of the control panel is indicated.

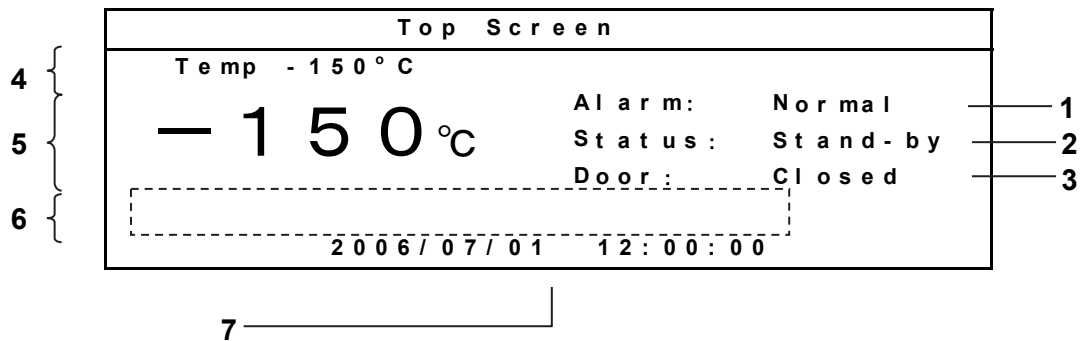

1. Display of alarm (Alarm): Normal condition: "Normal" is displayed.

Alarm-activated, buzzer-delayed: "Alarm" is displayed alternately in reversal/non-reversal character.

Alarm-activated, buzzer-sounding: "Warning" is displayed alternately in reversal/non-reversal character

The complementary message is indicated in the message indication.

- "Test" is displayed alternately by the reversal/non-reversal character during the alarm test.

2. Display of status (Status): Normal condition: "Stand-by" is displayed.

The status number is displayed and a complementary message is displayed in the message column when the operation monitor system detects the specified status. Refer to page 23 for the details.

3. Display of door status (Door): "Open" is highlighted when the door is open. When the door is close, "Closed" is displayed. (Normal character)

4. Display of setting (Temp): Set value of chamber temperature is displayed.

5. Display of present chamber temperature: Present value of chamber temperature is displayed.

6. Message indication: Various messages are indicated. Refer to page 23 and 24 for the details.

7. Display of date and time: The current date and time are displayed.

FUNCTION OF CONTROL PANEL

The following functions are available through control panel:

1. Setting of running operation: To set a running condition at the start-up. (refer to page 16)

2. Setting of log cycle and sending to PC: To set a log cycle of running data and to send a running log to PC. (page 19)

3. Setting of date and time: To set the date and time shown on the basic screen. (page 21)

4. Setting/display of alarm: High limit (or low limit) temperature setting (page 16). Power failure alarm (page 23) and filter alarm (page 23) are indicated.

5. Default setting: To set the default for LCD panel and communication (DAQ) speed etc. (page 20)

6. Alarm test: The test of alarm buzzer, alarm lamp and remote alarm is effective by pressing the alarm buzzer stop key (BUZZER) for about five seconds during normal operation. Pressing the key again finishes the alarm test.

RUNNING OPERATION (MENU/Set)

This product is operated with set temperature at the time of start-up.

1. With the basic screen displayed, press the menu button (MENU) to show the menu window. Select "Set", and press the enter key (ENTER).

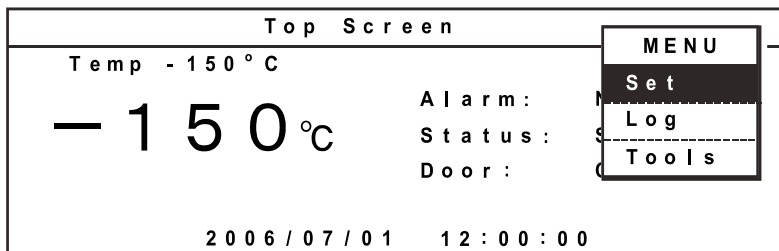

2. A temperature setup screen (Temp. Setting) is indicated. Set up each parameter.

Temp. Setting		
Temperature	- 150 °C	(- 125 ° C - 152 ° C)
High Alarm	+ 10 ° C	(+5 ° C - +20 ° C)
Low Alarm	- 10 ° C	(-5 ° C - -20 ° C)
Ring Back	30 min	(0 . OFF 1 - 99 min)
Alarm Delay	15 min	(0 - 15 min)
Key Lock	0	(0 . Unlock 1 . Lock)

3. Push the menu button (MENU) to finish the settlement of each parameter. Select OK on the menu window, and push the enter key (ENTER). The setting is memorized.

Each parameter setting range:

- Temperature : It is the set point of chamber temperature. Temperature settable range : -125 °C~ -152 °C (The factory setting is -150 °C.)
- High Alarm: It is the set point of the high temperature alarm. Temperature settable range: Chamber temperature +5 °C~+20 °C (The factory setting is +10 °C)
- Low Alarm: It is the set point of the low temperature alarm. Temperature settable range: Chamber temperature -5 °C~-20 °C (The factory setting is -10 °C)
- Ring Back: This is the duration between the stop of alarm buzzer and next start of alarm buzzer. The settable range is between 1 minute and 99 minutes. The alarm buzzer is not back again when the setting is 0. (The factory setting is 30 minutes)
- Alarm Delay: The settable range of the alarm delay time is between 0 and 15 minutes. With 0 setting, the alarm buzzer activates immediately without delay. (The factory setting is 15 minutes.)
- Key Lock: When "Lock" is chosen, a set point cannot be changed. The input of the password is necessary at the time of release.

Note : An alarm buzzer operates 15 minutes after it became a state of alarm. When the door is open, it is indicated on the basic screen (Door) by "Open" and the reversal character.

RUNNING OPERATION (MENU/Set)

Key lock function

1. On the temperature setting screen (Temp. setting), input 1 in the “Key Lock” field. Press the enter key (ENTER) and the buzzer sounds shortly and the key lock is effective.

Temp. Setting		
Temperature	- 150 °C	(- 125 °C - 152 °C)
High Alarm	+ 10 °C	(+5 °C - +20 °C)
Low Alarm	- 10 °C	(-5 °C - -20 °C)
Ring Back	30min	(0. OFF 1 - 99min)
Alarm Delay	15min	(0 - 15min)
Key Lock	0	(0. Unlock 1. Lock)

2. “Key Lock” is indicated on the top line. The change of setting is impossible.

Temp. Setting	Key Lock	
Temperature	- 150 °C	(- 125 °C - 152 °C)
High Alarm	+ 10 °C	(+5 °C - +20 °C)
Low Alarm	- 10 °C	(-5 °C - -20 °C)
Ring Back	30min	(0. OFF 1 - 99min)
Alarm Delay	15min	(0 - 15min)
Key Lock	1	(0. Unlock 1. Lock)

Key lock release function

1. On the temperature setting screen (Temp. Setting), input 0 in the “Key Lock” field, and press the enter key (ENTER).

Temp. Setting	Key Lock	
Temperature	- 150 °C	(- 125 °C - 152 °C)
High Alarm	+ 10 °C	(+5 °C - +20 °C)
Low Alarm	- 10 °C	(-5 °C - -20 °C)
Ring Back	30min	(0. OFF 1 - 99min)
Alarm Delay	15min	(0 - 15min)
Key Lock	1	(0. Unlock 1. Lock)

2. The cursor is moved to the password column (Password). Input 4-digit password and press the enter key (ENTER). The buzzer sounds shortly and the key lock is released. The “Key Lock” indication of the temperature setting screen (Temp. Setting) disappears.

Temp. Setting	Key Lock	
Temperature	- 150 °C	(- 125 °C - 152 °C)
High Alarm	+ 10 °C	(+5 °C - +20 °C)
Low Alarm	- 10 °C	(-5 °C - -20 °C)
Ring Back	30min	(0. OFF 1 - 99min)
Alarm Delay	15min	(0 - 15min)
Key Lock	0	Password ■■■■

Note : The buzzer sounds if a password is wrong. Again, input a password. A user should manage a password with all of the members. Factory setting is 0000. Refer to page 22.

VARIOUS SETTING (MENU/Log)

Display of log(Log)

1. On the basic screen, press the menu button (MENU) to show the menu window. Select log, and press the enter key (ENTER).

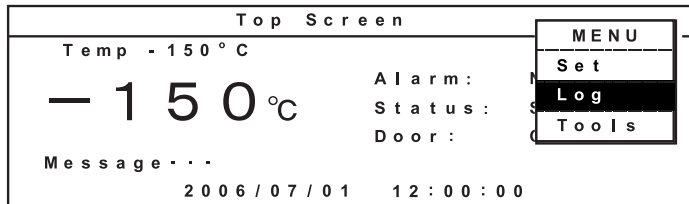

2. When accumulated data (for one day) are transmitted to the PC: Press the menu (MENU), select "PC 1D" and press the enter key (ENTER). When all accumulated data are transmitted to the PC: Press the menu button(MENU), select "PC ALL" and press the enter key (ENTER). All accumulated records are indicated with a dot. A graph display (PC 1D) is indicated. (1 page 24-hour indication)

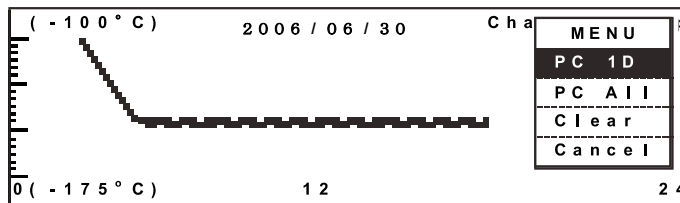

3. Data transmitting screen is indicated. Specify a transfer, a capture of the textbook and a preservation file name by the operation on the PC side hyper-terminal. Specify the extension of the preservation file name with txt or csv. Press the menu button (MENU), select "start" and press the enter key (ENTER). The transmission is started. The transmission is finished when a finished message comes out.

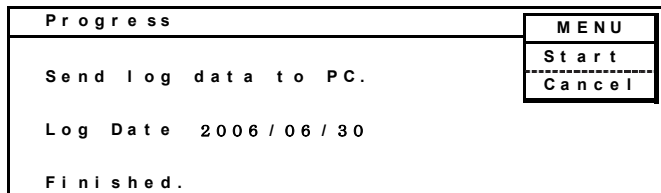

Each parameter setting range:

- Temperature range is changed with ↓↑. Temperature :50 °C~-25 °C,-25 °C~-100 °C,-100 °C~-175 °C

- It is moved with ← and → to date. (←: Past date, →: New date)

- A data interval is 2 minutes from 30 minutes. (The factory setting is 15 min.)

With 15 minutes interval, the recording for about 5 weeks is available. With 6 minutes interval, the recording for about 2 weeks is possible.

- Pop-up screen is indicated when "PC 1D" is selected. Log data on date (for 1 day) indicated.

- Pop-up screen is indicated when "PC ALL" is selected and all memory log data are transmitted.

- Pop-up screen is indicated when the clear key (CE) is pushed. All log data are erased when OK is selected by pop-up MENU.

Note :

- When log data are full, it is erased automatically in order from the old data.

- The communication cable for the interface board MTR-480 of the option and 9 pin Dsub cross type for RS232C is necessary for the data transmission to the PC. Refer to page 40 for the details.

VARIOUS SETTING (MENU/Log)

The operation of the hyper-terminal on the PC side

1. Transmission starts when a transfer, a capture of the text and a preservation file name are specified and MENU/Start is selected.
2. The transmission is finished, with "Finished" indication.

PC setting

As for setting in PC side for transmission of log data, please contact our sales representative or agent.

VARIOUS SETTING (MENU/Tools)

Various numerical value can be changed from Tools.

1. On the basic screen, press the menu button (MENU), select "Tools" and press the enter key (ENTER). The setting screen "Select Tools" is displayed.

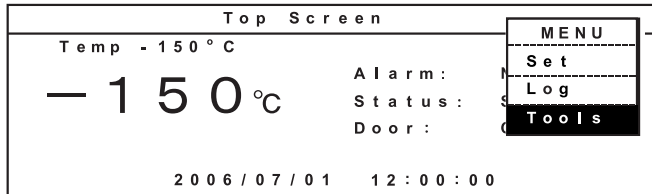

2. Select the item to be set and press the enter key (ENTER).

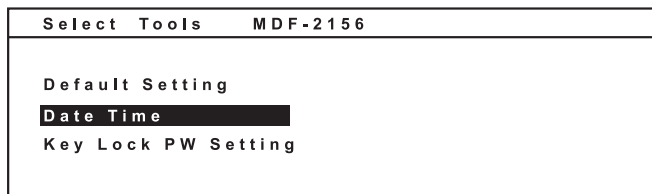

Initialization(Tools/Default Setting)

1. The settlement of each parameter can be done on the default setting screen (Default Setting). (The following shows the default setting)

Default Setting	
LCD Back Color	1 (1. Blue 2. White)
DAQ Speed	0 (0. 2400 2. 9600)
DAQ ID	0 (0. OFF 1- 250)
DAQ Mode	0 (0. Local 1. Remote)
Filter Buzzer	1 (0. OFF 1. Active)
Remote Alarm	1 (0. OFF 1. Active)

Each parameter setting range:

- LCD Back Color : Setup of the back light (1. Blue 2. White)
- DAQ Speed should use 0, "2400". It is DAQ standard command mode.
- DAQ ID: select any ID between 1 and 250 when an optional interface board is attached.
- DAQ Mode: "0" setting change from PC side is impossible. "1" change of temperature on the stand-by setting" screen is impossible. "Remote" is indicated on the upper right of the "Stand-by setting" screen. DAQ Mode is effective when DAQ speed is 0 or 2.
- Filter Buzzer can select ON-OFF of the buzzer sound at the time of the filter alarm.
- Remote Alarm can select ON-OFF of the remote alarm contact at the time of the alarm.

2. After setting, press the menu button (MENU), select "OK" and press the enter key (ENTER) The setting is memorized.

VARIOUS SETTING (MENU/Tools)

Setting of date, time, log interval(Tools/Date Time)

1. On the setting screen (Select Tools), select “Data Time”, and press the enter key (ENTER). A date, time and a log interval setup screen (Data Time) is indicated. Set up each parameter.

Date Time	
Date	06 / 07 / 01 (YY / MM / DD)
Time	12 : 00 : 00 (hh : mm : ss)
Door Delay	2 min (1 - 15 min)
Log Interval	15 min (2 - 30 min)
Comp Delay	2 min (2 - 15 min)

Each parameter setting range:

- July 1st, 2006 12:00:00 is set.

It is input with 060701 in the Date cell.

It is input with 120000 in the Time cell.

It is set up with MENU/ OK (ENTER).

- Door Delay: The settable range of the door alarm delay time is 1 minute and 15 minutes. (The factory setting is 2 minutes)

- Log Interval: Settable between 2 minutes and 30 minutes. (Factory setting is 15 minutes.) With 15 minutes interval, recording for about 5 weeks is available.

- Comp Delay: Delay time for high temperature side/low temperature side compressor after power failure. The settable range is between 2 minutes and 15 minutes. (Factory setting is 2 minutes.)

2. After setting, press the menu button (MENU), select “OK” and press the enter key (ENTER). The setting is memorized.

VARIOUS SETTING (MENU/Tools)

Setting of key lock password(Tools/Key Lock PW Setting)

1. On the setting screen (Select Tools), select “Key Lock PW Setting”, and press the enter key (ENTER).
Input the present password (4 digits), and press the enter key (ENTER). (Factory setting is 0000.)

Key Lock PW Setting	
Current User Password	████

2. Input a new password, and press the enter key (ENTER).

Key Lock PW Setting	
New User Password	████

3. Input the password again, and press the enter key (ENTER).

Key Lock PW Setting	
New User Password	****
Re Enter User Password	████

ALARM BUZZER

- Temperature alarm buzzer (intermittent tone)

It is informed with the intermittent tone of the buzzer when a high temperature alarm (High Alarm) or a low temperature alarm (Low Alarm) occur.

Buzzer informs it with the intermittent sound when an alarm condition goes on for more than fifteen minutes. Push alarm buzzer stop key (BUZZER) to stop the alarm. The alarm buzzer sounds again if an alarm is not solved in the time when it is set up with Ring Back. When alarm sounds, a remote alarm is activated, too.

- Door alarm buzzer (intermittent tone)

It is informed with the intermittent tone if it is the condition that the door opens beyond the time when it is set up with Door Delay. It stops if a door is closed.

- Filter alarm buzzer (intermittent tone)

It is informed with the intermittent tone when the temperature of filter sensor is beyond +48.0 °C

Buzzer sound stops when the temperature of the filter sensor is less than +43.0 °C

- ◆:Buzzer stops if the alarm buzzer stop key (BUZZER) is pushed when an alarm occurs and a buzzer sounds.

MONITOR OF FREEZER STATUS

This product has the operation monitor system which shows it in the table 1. It is the system to inform it of the operation conditions of the product. Operation conditions are indicated in the Status indication of the basic screen and the message indication.

Table 1 Operation monitor system(STATUS) list

Kind of function	Status	Indication	If this status continues	Remedy
Notice of abnormal ambient temperature	When the ambient temp. is over approx. 35 °C or lower than about 0 °C.	STATUS indication : "Status_1" is indicated. Message indication : "Ambient temp is abnormal." is indicated.	Decrease of cooling performance or durability of refrigerating circuit.	Recheck air-conditioning of installed site.
Notice of low voltage	When the power source voltage is less than approx. 195 V when the rated voltage is between 220 and 240 V.	STATUS indication : "Status_2" is indicated. Message indication : "The Power-supply is abnormal." is indicated.	Abnormal heat at power supply outlet or degrade of starting performance of refrigerating circuit	Use dedicated power source.

Note :

- Buzzer operation and a remote alarm can not be done with the monitor of the freezer status.
- STATUS indicates only "STATUS_1" when two problems occur in the monitor of the freezer status. STATUS indicated is to cope with it.

ALARMS & SAFETY FUNCTIONS

This product has the alarm & safety function of the table 2.

Table 2. Alarm & safety function list

Alarm & safety	Situation	Indication	Buzzer	Safety operation
High temp. alarm	If the chamber temperature is higher than the temperature at which the high temperature alarm is activated.	Alarm lamp flashed Temp. indicator is flashed Message indication: "High Temp Warning 20XX/XX/XX XX:XX:XX"	Intermittent tone with 15 minutes delay	Remote alarm with 15 minutes delay
Low temp. alarm	If the chamber temperature is lower than the temperature at which the low temperature alarm is activated.	Alarm lamp flashed Temp. indicator is flashed Message indication: "Low Temp Warning 20XX/XX/XX XX:XX:XX"		
Power failure alarm	When the power to the unit is disconnected.	Alarm lamp flashed Message indication: Power failure Warning 20XX/XX/XX XX:XX:XX (The chamber temp. is displayed by pressing the alarm buzzer stop key.)	Intermittent tone	Remote alarm
Door alarm	When door is open.	"Open" is highlighted in the door status display.	Intermittent tone with 2 minutes delay	----
Filter alarm	When the condenser filter is clogged.	Alarm lamp flashed Message indication: "Please check a condenser filter."	Intermittent tone ON/OFF can be set up	----

Note : A message and an alarm date indicate it in the indication of the high temperature alarm/low temperature alarm/blackout alarm. And, message indication is indicated until an alarm buzzer stop key (BUZZER) is pushed.

ALARMS & SAFETY FUNCTIONS

Table 2. Alarms & safety function list

Alarm & safety	Situation	Indication	Buzzer	Safety operation
Operation memory	Record of chamber condition during the power failure. The memory of the set point before the power failure.	----	----	The set value is memorized by nonvolatile memory. The freezer resumes the operation with setting before power failure.
Key lock	When the key lock is on.	----	----	Setup can not be changed.
Auto-return	When there is no key pressing in each setting mode for 90 seconds.	Chamber temperature is displayed.	----	Finishing of each setting mode.
Battery check	When about 3 years has passed with power switch ON.	Message indication: "Please exchange batteries."	----	----
Fan motor check	When a power switch was turned on and it passed for about 6 years.	Message indication: "Please exchange a fan motor."	----	----
Sensor abnormality	If the thermal sensor is disconnected.	Message indication: "Error #01 Temp Sensor is Open."	Intermittent tone	Remote alarm. Unit keeps continuous running.
	If the thermal sensor is short-circuited.	Message indication: "Error #02 Temp Sensor is Short."	Intermittent tone	Remote alarm. Unit keeps continuous running.
	If the cascade sensor is disconnected.	Message indication: "Error #03 Cascade Sensor is Open."	Intermittent tone	Remote alarm.
	If the cascade sensor is short circuited.	Message indication: "Error #04 Cascade Sensor is Short."	Intermittent tone	Remote alarm.
	If the filter sensor is disconnected.	Message indication: "Error #05 Filter Sensor is Open."	Intermittent tone	Remote alarm.
	If the filter sensor is short-circuited.	Message indication: "Error #06 Filter Sensor is Short."	Intermittent tone	Remote alarm.
	If the ambient temperature sensor is disconnected.	Message indication: "Error #07 Ambient temp Sensor is Open."	Intermittent tone	Remote alarm.
	If the ambient temperature sensor is short-circuited.	Message indication: "Error #08 Ambient temp Sensor is Short."	Intermittent tone	Remote alarm.
Battery switch check	When the battery switch is OFF during alarm test.	Message indication: "Error #09 Battery switch is off."	----	----
Condenser temp. abnormality	In the event of failure of fan motor for cooling the compressor. When the ambient temperature exceeds the usable environmental condition, etc.	Message indication: "Error #10 Condenser temp. is abnormal."	Intermittent tone	Remote alarm. Compressor of high temp. side stops.

Note:

- When the operation is started in high ambient temperature, the alarm lamp (ALARM) sometimes flashes, and then the message (Please check a condenser filter) of the filter alarm is indicated on it in the basic screen. In this case, the lamp is off automatically when the chamber temperature is getting lower.
- The freezer resumes the operation after power failure with the temperature setting before power failure as the chamber temperature setting and alarm temperature setting are memorized in the nonvolatile memory.
- The chamber temperature is displayed for 5 seconds by pressing buzzer stop key (BUZZER) during power failure alarm. Then the buzzer is silenced. The alarm lamp keeps flashing.

REMOTE ALARM TERMINAL

The terminal of the remote alarm is installed at the panel door inside of the unit. The alarm is outputted from this terminal. Contact capacity is DC 30 V, 2 A.

Contact output:

	between COM. and N.O.	between COM. and N.C.
At normal	Open	Close
At abnormal	Close	Open

Note:

The alarm is actuated when the power supply cord is disconnected from the outlet or the power switch is OFF.

ANALOG OUTPUT TERMINAL

The analog output terminals can output the chamber temperature as a voltage signal. The output range is between 0 mV and 100 mV.

	Range	Output
Temp.	-160 °C~+40 °C	0.5 mV/°C

(Example)

Output at -150 °C: $(-150\text{ °C} - 160\text{ °C}) \times 0.5\text{ mV/°C} = 5\text{ mV}$

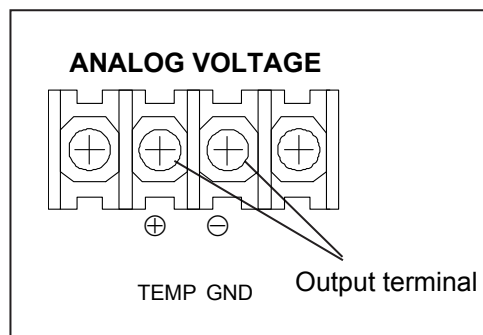

BACKUP COOLING KIT

The holding time of chamber temperature(-135 °C) due to the change in the ambient temperature. (Liquid nitrogen : 50 L x 2, no-load)

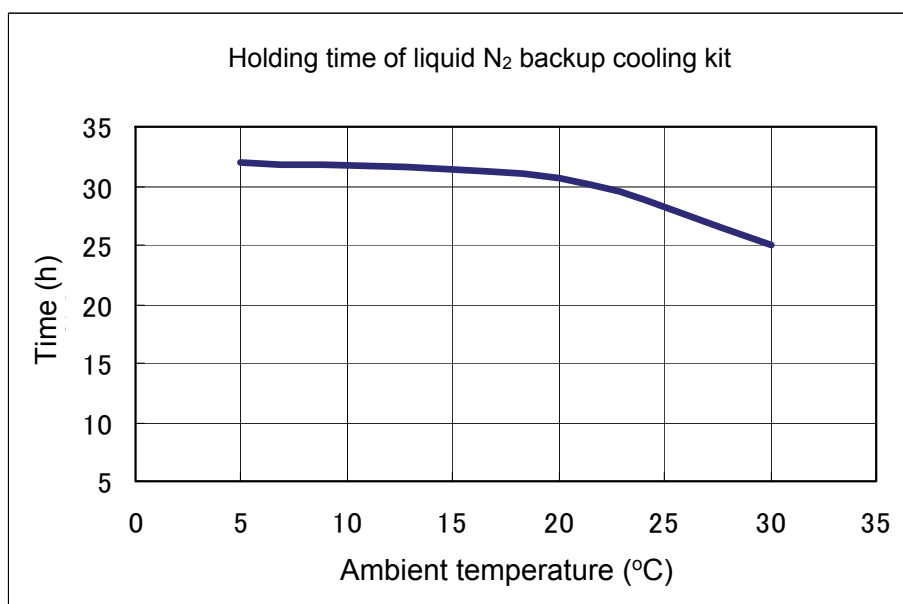

• The above data is the experiment value which uses liquid N₂ 100 L. (no-load)

BACKUP COOLING KIT

WARNING

As with any equipment that uses N₂ gas, there is a likelihood of oxygen depletion in the vicinity of the equipment. It is important that you assess the work site to ensure there is suitable and sufficient ventilation. If restricted ventilation is suspected, then other methods of ensuring a safe environment must be considered. These may include atmosphere monitoring and warning devices.

The freezer is provided with an automatic liquid N₂ injection device as a backup cooling kit. This freezer prevents the chamber temperature from going up by injecting the liquid N₂ when the power supply is disconnected (power failure, disconnection of power supply cord, breaker OFF) or in the case of failure of freezer itself. The liquid N₂ is injected with the activation of solenoid valve energized by battery when the chamber temperature reaches the temperature set by the temperature control knob. Following shows the procedure for setting the backup cooling kit.

1. Connect the liquid N₂ cylinder with the backup cooling kit joint by using the enclosed connect tube for backup cooling kit. This work should be done by high pressure gas works specialists. The pressure of liquid N₂ cylinder should be regulated at 49.0 kPa(G) (0.5 kgf/cm²(G)).
2. Operate the freezer until the freezer temperature reaches the set temperature.
3. Set the temperature control knob at 15°C higher than the freezer set temperature.
4. Turn on the backup switch. The backup cooling kit is in standby status.
5. Make sure that liquid N₂ spouts into the chamber with the backup test switch.
6. The liquid N₂ in the cylinder is decreased due to natural evaporation even if it is not used for backup. Mind to check the liquid N₂ level in the cylinder.

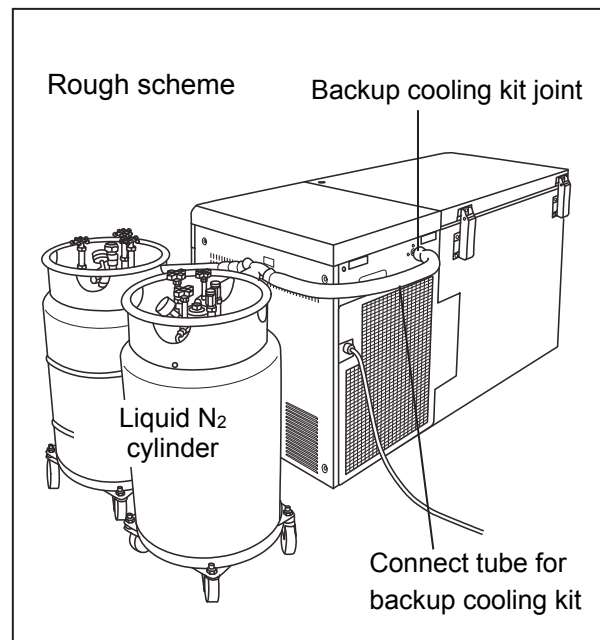

Note:

- Use a dedicated insulated container for storing the liquid N₂.
- Use a container with an adjustable pressure valve for storing the liquid N₂. The pressure should be adjustable between 49.0 kPa(G) and 68.6 kPa(G) (0.5 kgf/cm²(G)~0.7 kgf/cm²(G)).
- Use the connect tube for backup cooling kit enclosed with the freezer for the setting. (The extension of the connect tube for backup cooling kit is not permitted because of cooling capacity.)
- Turn off a backup switch when the operation of the freezer is suspended and when a backup cooling kit is not used. A battery for the backup cooling kit discharges electricity with on.

ROUTINE MAINTENANCE

⚠ WARNING

Always disconnect the power supply to the unit prior to any repair or maintenance of the unit in order to prevent electric shock or injury.

Ensure you do not inhale or consume medication or aerosols from around the unit at the time of maintenance. These may be harmful to your health.

Cleaning of cabinet

- Clean the unit once a month. Regular cleaning keeps the unit looking new.
- Use a dry cloth to wipe off small amounts of dirt on the outside and inside of the unit and all accessories. If the outside panels are dirty, clean them with a diluted neutral dishwashing detergent. (Undiluted detergent can damage the plastic components. For the dilution, refer to the instruction of the detergent.) After the cleaning with the diluted detergent, always wipe it off with a wet cloth. Then wipe off the cabinet or accessories with a dry cloth.
- Never pour water onto or into the unit. Doing so can damage the electric insulation and cause failure.
- The compressor and other mechanical parts are completely sealed. This unit requires absolutely no lubrication.
- Check the backup cooling kit by pressing test switch once a month if it is installed.
- Remove the frost or ice on the chamber wall and clean the condenser filter once a month.

Cleaning of condenser filter

This unit displays a message to notify the condenser filter clogging in the message indication on the LCD panel. Clean the condenser filter when the alarm lamp blinks and “Please check a condenser filter.” is displayed. Clean the filter once a month even if the alarm lamp is not on since a clogged filter may cause shorter compressor life as well as the poor cooling.

Clean the filter by the procedure below.

1. Open the grille by pulling it to you as shown in the figure.
2. Take out the condenser filter.
3. Wash the filter with water.
4. Replace the filter and the grille.
5. After cleaning the condenser filter, check the alarm lamp and the message are off.

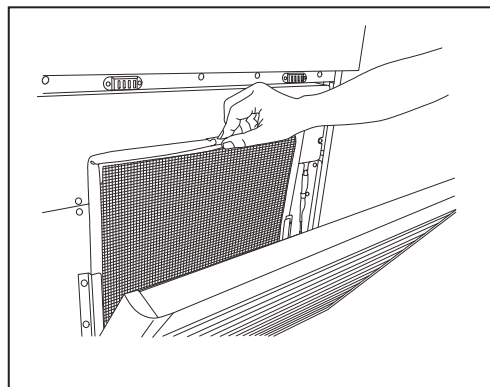

⚠ WARNING

Do not touch the condenser directly when the filter is removed for cleaning. This may cause injury by hot surface.

ROUTINE MAINTENANCE

Defrosting of inside wall

Defrost the inside wall of the freezer as follows:

Normal defrosting

Remove the frost by the enclosed scraper.

Thorough defrosting

1. Take out and transfer all the contents to another freezer or container which contains liquid N₂, or dry ice. Switch off the remote alarm and backup cooling kit. Switch off the power supply.
2. Open the door and remove the inner lid. Leave the freezer as it is. The water remaining in the freezer compartment should be wiped up.
3. After cleaning is completed, restart the operation according to the procedure. Put back the articles into the sufficiently cooled freezer compartment.

REPLACEMENT OF BATTERY

[For service personnel only]

The battery for power failure alarm is an article for consumption. The battery life is approximately 3 years. The buzzer cannot be activated at the power failure and the stored items may be influenced if the battery is left as it is for more than 3 years. It is recommended that the battery is replaced ahead of time. For the replacement of the battery, contact our sales representative or agent.

Location of a lead storage battery

This unit is provided a lead storage battery for the power failure warning device. The battery is located in the battery box inside the side table. (Fig. 1)

	The high voltage components are enclosed in the battery box. The cover should be removed by a qualified engineer or service personnel only to prevent the electric shock.
---	---

Removal of lead storage battery

1. Turn off the power switch, battery switch and disconnect the power supply plug.
2. Lift the handle of the side table to the top as shown in the fig. 2, and open the door of the side table. Remove 6 screws of the battery box cover, and remove a battery box cover.
3. Remove 4 screws which fix a battery bracket on the side table. (Fig. 3)
4. Remove the connector of the battery, and take out a battery bracket from the side table. And remove 4 screws of the battery bracket which fixes a battery (4 pcs). (Fig. 4)

Handling of the lead storage battery:

Cover the battery terminal with an insulating tape to avoid the short circuit. Then follow the procedure for recycling or proper disposal.

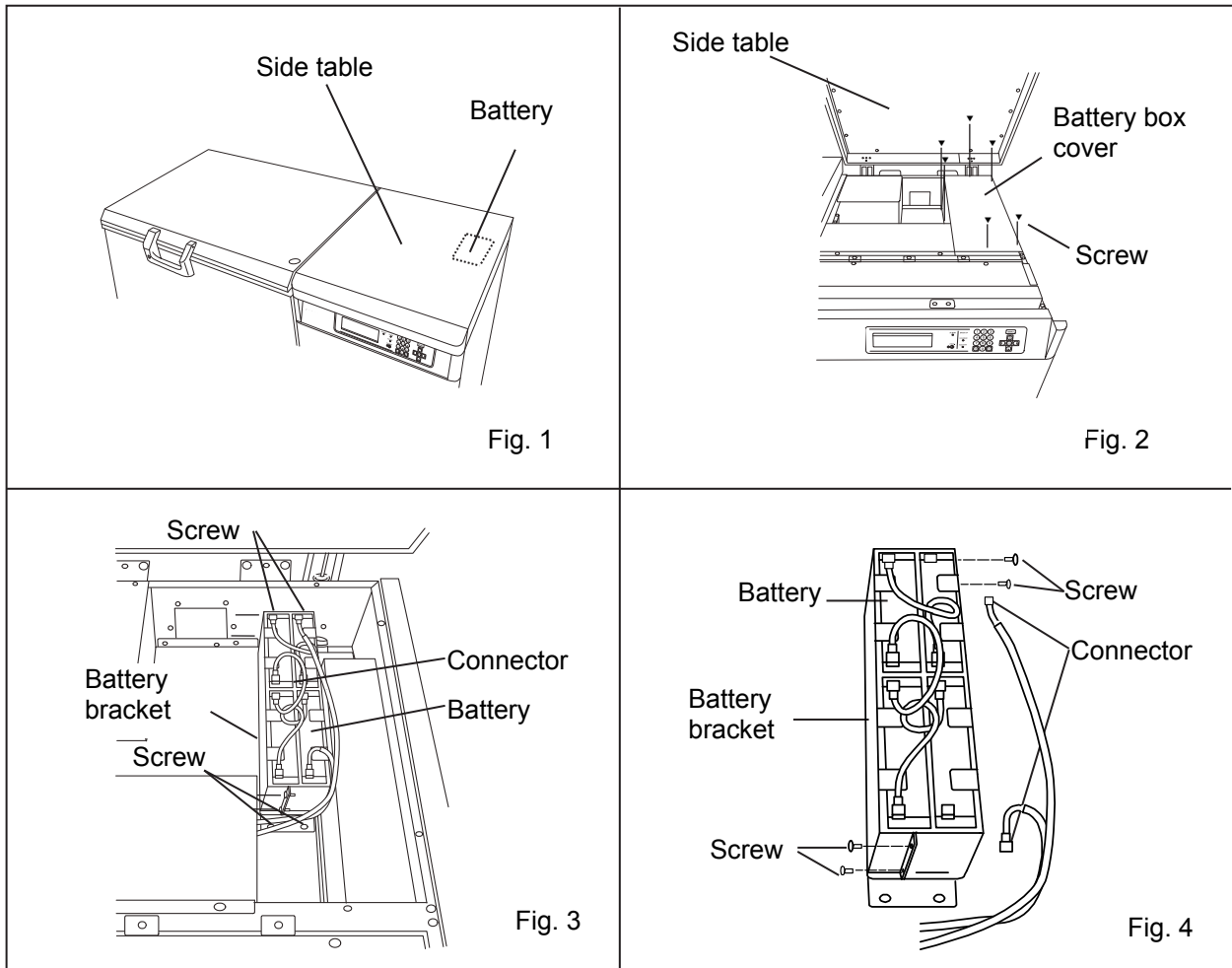

TROUBLESHOOTING

If the unit malfunctions, check out the following before calling for service.

Malfunction	Check/Remedy
If nothing operates even when switched on	<ul style="list-style-type: none"> ■ The unit is not connected to the power supply. ■ There is a power failure. ■ The fuse is blown or the circuit breaker is activated.
An alarm system works	<ul style="list-style-type: none"> ■ Investigate the following cause when an alarm lamp and buzzer sound are working. ■ When use starts. Is temperature of the freezer chamber the value? ■ When it is using. Were not you taking the condition that opened the change of the temperature command and a door for a long time? Did not you put the sample whose temperature was high in the freezer chamber? <p>An alarm is canceled naturally when it is left in these cases.</p>
The cooling is poor	<ul style="list-style-type: none"> ■ The environmental temperature is too high. ■ The door is not shut tightly. ■ The inner lid is not installed correctly. ■ The set temperature is not set properly. ■ The grille is blocked out. ■ The filter is clogged. ■ The freezer is in the direct sunlight. ■ There is any heating source near the freezer. ■ A rubber cap and insulation for the access port are not set correctly. ■ You put too many unfrozen articles into the freezer compartment.
There is condensation outside the freezer	<ul style="list-style-type: none"> ■ The condensation can be found outside the freezer depending on the installation site, or under muggy environment. The condensation is caused by the humidity not by freezer failure. <p>Wipe off the condensation with a dry cloth.</p>

Note:

If the malfunction is not eliminated after checking the above items, or the malfunction is not shown in the above table, contact our sales representative or agent.

DISPOSAL OF UNIT

WARNING

If the unit is to be stored unused in an unsupervised area for an extended period **ensure that children do not have access and doors cannot be closed completely.**

The disposal of the unit should be accomplished by appropriate personnel. Always remove doors to prevent accidents such as suffocation.

Recycle of battery

(Only for USA and CANADA)

A sealed lead acid battery that is recyclable powers the product you have purchased. At the end of its useful life, under various state and local laws, it is illegal to dispose of this battery into your municipal waste stream. Please call 1-800-SAV-LEAD for information on how to recycle this battery.

L'appareil que vous vous êtes procuré est alimenté par une batterie au plomb étanche. Après la fin de la vie utile de la batterie, en vertu de diverses réglementations gouvernementales et locales, il est illégal de l'éliminer avec les déchets domestiques ordinaires. Pour des renseignements sur le recyclage de la batterie, veuillez composer le 1-800-SAV-LEAD.



Pb

- USE THE SPECIFIED CHARGER.



- Label indication is obliged to comply with Taiwanese battery regulation.

(Apenas para a Brasil)



CHUMBO

Baterias de chumbo – ácido:

Atenção sobre a bateria:

- Após o uso, a bateria deverá ser devolvida à rede de assistência técnica ou revendedores para ser encaminhada ao fabricante ou importador.
(Resolução CONAMA ns° 401)
- **Riscos a saúde:** O contato com os componentes químicos internos desta bateria pode causar danos a saúde.
- **Riscos ao meio-ambiente:** A destinação final inadequada pode poluir águas e solo.
- **Composição básica:** Chumbo, ácido sulfúrico diluído e plástico.

DISPOSAL OF UNIT

(English)

Disposal of Old Equipment and Batteries

Only for European Union and countries with recycling systems



These symbols on the products, packaging, and/or accompanying documents mean that used electrical and electronic products and batteries must not be mixed with general household waste.

For proper treatment, recovery and recycling of old products and used batteries, please take them to applicable collection points in accordance with your national legislation.



By disposing of them correctly, you will help to save valuable resources and prevent any potential negative effects on human health and the environment.

For more information about collection and recycling, please contact your local municipality.



Penalties may be applicable for incorrect disposal of this waste, in accordance with national legislation.

Note for the battery symbol (bottom symbol):

This symbol might be used in combination with a chemical symbol. In this case it complies with the requirement set by the Directive for the chemical involved.

Pb

(German)

Entsorgung von Altgeräten und Batterien

Nur für die Europäische Union und Länder mit Recyclingsystemen



Dieses Symbol, auf den Produkten, der Verpackung und/oder den Begleitdokumenten, bedeutet, dass gebrauchte elektrische und elektronische Produkte sowie Batterien nicht in den allgemeinen Hausmüll gegeben werden dürfen.

Bitte führen Sie alte Produkte und verbrauchte Batterien zur Behandlung, Aufarbeitung bzw. zum Recycling gemäß den gesetzlichen Bestimmungen den zuständigen Sammelpunkten zu. Endnutzer sind in Deutschland gesetzlich zur Rückgabe von Altbatterien an einer geeigneten Annahmestelle verpflichtet. Batterien können im Handelsgeschäft unentgeltlich zurückgegeben werden.



Indem Sie diese Produkte und Batterien ordnungsgemäß entsorgen, helfen Sie dabei, wertvolle Ressourcen zu schützen und eventuelle negative Auswirkungen auf die menschliche Gesundheit und die Umwelt zu vermeiden.

Für mehr Informationen zu Sammlung und Recycling, wenden Sie sich bitte an Ihren örtlichen Abfallentsorgungsdienstleister.

Gemäß Landesvorschriften können wegen nicht ordnungsgemäßer Entsorgung dieses Abfalls Strafgebühren verhängt werden.



Hinweis für das Batteriesymbol (Symbol unten):

Dieses Symbol kann in Kombination mit einem chemischen Symbol abgebildet sein. In diesem Fall erfolgt dieses auf Grund der Anforderungen derjenigen Richtlinien, die für die betreffende Chemikalie erlassen wurden.

Pb

DISPOSAL OF UNIT

(French)

L'élimination des équipements et des batteries usagés

Applicable uniquement dans les pays membres de l'Union européenne et les pays disposant de systèmes de recyclage.



Apposé sur le produit lui-même, sur son emballage, ou figurant dans la documentation qui l'accompagne, ce pictogramme indique que les piles, appareils électriques et électroniques usagés, doivent être séparées des ordures ménagères.



Afin de permettre le traitement, la valorisation et le recyclage adéquats des piles et des appareils usagés, veuillez les porter à l'un des points de collecte prévus, conformément à la législation nationale en vigueur.



En les éliminant conformément à la réglementation en vigueur, vous contribuez à éviter le gaspillage de ressources précieuses ainsi qu'à protéger la santé humaine et l'environnement.

Pour de plus amples renseignements sur la collecte et le recyclage, veuillez vous renseigner auprès des collectivités locales.



Le non-respect de la réglementation relative à l'élimination des déchets est passible d'une peine d'amende.

Note relative au pictogramme à apposer sur les piles (pictogramme du bas) :

Si ce pictogramme est combiné avec un symbole chimique, il répond également aux exigences posées par la Directive relative au produit chimique concerné.

Pb

(Spanish)

Eliminación de Aparatos Viejos y de Pilas y Baterías

Solamente para la Unión Europea y países con sistemas de reciclado.



Estos símbolos en los productos, su embalaje o en los documentos que los acompañen significan que los productos eléctricos y electrónicos y pilas y baterías usadas no deben mezclarse con los residuos domésticos.



Para el adecuado tratamiento, recuperación y reciclaje de los productos viejos y pilas y baterías usadas llévelos a los puntos de recogida de acuerdo con su legislación nacional. En España, los usuarios están obligados a entregar las pilas en los correspondientes puntos de recogida. En cualquier caso, la entrega por los usuarios será sin coste alguno para éstos. El coste de la gestión medioambiental de los residuos de pilas, acumuladores y baterías está incluido en el precio de venta.



Si los elimina correctamente ayudará a preservar valuosos recursos y evitará potenciales efectos negativos sobre la salud de las personas y sobre el medio ambiente.

Para más información sobre la recogida u reciclaje, por favor contacte con su ayuntamiento.

Puede haber sanciones por una incorrecta eliminación de este residuo, de acuerdo con la legislación nacional.

Nota para el símbolo de pilas y baterías (símbolo debajo):

Este símbolo puede usarse en combinación con el símbolo químico. En este caso, cumple con los requisitos de la Directiva del producto químico indicado.

Pb

DISPOSAL OF UNIT

(Portuguese)

Eliminação de Equipamentos Usados e Baterias

Apenas para a União Europeia e países com sistemas de reciclagem



Estes símbolos nos produtos, embalagens, e/ou documentos que os acompanham indicam que os produtos elétricos e eletrónicos e as baterias usados não podem ser misturados com os resíduos urbanos indiferenciados.



Para um tratamento adequado, reutilização e reciclagem de produtos e baterias usados, solicitamos que os coloque em pontos de recolha próprios, em conformidade com a respetiva legislação nacional.



Ao eliminar estes produtos corretamente estará a ajudar a poupar recursos valiosos e a prevenir quaisquer potenciais efeitos negativos sobre o ambiente e a saúde humana.

Para mais informações acerca da recolha e reciclagem, por favor contacte a sua autarquia local.



De acordo com a legislação nacional podem ser aplicadas contraordenações pela eliminação incorreta destes resíduos.

Nota para o símbolo da bateria (símbolo na parte inferior):

Este símbolo pode ser utilizado conjuntamente com um símbolo químico. Neste caso estará em conformidade com o estabelecido na Diretiva referente aos produtos químicos em causa.

Pb

(Italian)

Smaltimento di vecchie apparecchiature e batterie usate

Solo per Unione Europea e Nazioni con sistemi di raccolta e smaltimento



Questi simboli sui prodotti, sull'imballaggio e/o sulle documentazioni o manuali accompagnanti i prodotti indicano che i prodotti elettrici, elettronici e le batterie usate non devono essere buttati nei rifiuti domestici generici.



Per un trattamento adeguato, recupero e riciclaggio di vecchi prodotti e batterie usate vi invitiamo a portarli negli appositi punti di raccolta secondo la legislazione vigente nel vostro paese.



Con uno smaltimento corretto, contribuirete a salvare importanti risorse e ad evitare i potenziali effetti negativi sulla salute umana e sull'ambiente.

Per ulteriori informazioni su raccolta e riciclaggio, vi invitiamo a contattare il vostro comune.



Lo smaltimento non corretto di questi rifiuti potrebbe comportare sanzioni in accordo con la legislazione nazionale.

Note per il simbolo batterie (simbolo sotto):

Questo simbolo può essere usato in combinazione con un simbolo chimico. In questo caso è conforme ai requisiti indicati dalla Direttiva per il prodotto chimico in questione.

Pb

DISPOSAL OF UNIT

(Dutch)

Het ontdoen van oude apparatuur en batterijen.

Enkel voor de Europese Unie en landen met recycle systemen.



Deze symbolen op de producten, verpakkingen en/of begeleidende documenten betekenen dat gebruikte elektrische en elektronische producten en batterijen niet samen mogen worden weggegooid met de rest van het huishoudelijk afval.



Voor een juiste verwerking, hergebruik en recycling van oude producten en batterijen, gelieve deze in te leveren bij de desbetreffende inleverpunten in overeenstemming met uw nationale wetgeving.



Door ze op de juiste wijze weg te gooien, helpt u mee met het besparen van kostbare hulpbronnen en voorkomt u potentiële negatieve effecten op de volksgezondheid en het milieu.

Voor meer informatie over inzameling en recycling kunt u contact opnemen met uw plaatselijke gemeente.



Afhankelijk van uw nationale wetgeving kunnen er boetes worden opgelegd bij het onjuist weggooien van dit soort afval.

Pb

Let op: het batterij symbool (Onderstaand symbool).

Dit symbool kan in combinatie met een chemisch symbool gebruikt worden. In dit geval volstaan de eisen, die zijn vastgesteld in de richtlijnen van de desbetreffende chemische stof.

(Swedish)

Avfallshantering av produkter och batterier

Endast för Europeiska Unionen och länder med återvinningssystem



Dessa symboler på produkter, förpackningar och/eller medföljande dokument betyder att förbrukade elektriska och elektroniska produkter och batterier inte får blandas med vanliga hushållssopor.



För att gamla produkter och använda batterier ska hanteras och återvinnas på rätt sätt ska dom lämnas till passande uppsamlingsställe i enlighet med nationella bestämmelser.



Genom att ta göra det korrekt hjälper du till att spara värdefulla resurser och förhindrar eventuella negativa effekter på människors hälsa och på miljön.

För mer information om insamling och återvinning kontakta din kommun.



Olämplig avfallshantering kan beläggas med böter i enlighet med nationella bestämmelser.

Pb

Notering till batterisymbolen (nedanför):

Denna symbol kan användas i kombination med en kemisk symbol. I detta fall uppfyller den de krav som ställs i direktivet för den aktuella kemikalien.

TEMPERATURE RECORDER (OPTION)



WARNING

Disconnect the power supply plug before attaching the temperature recorder or it may cause electric shock or fire.

The temperature recorder is available for this freezer as the optional component. The type of the recorder is MTR-155H. Consult our sales representative or agent for the recorder installation. Following shows the installation procedure.

<The installation method of MTR-155H>

1. Remove four screws (shown by arrows) on the front. After that, remove a temperature recorder cover (4 screws).

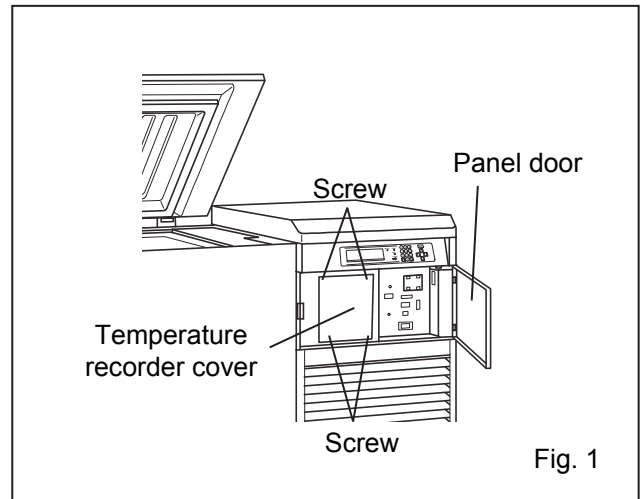

2. Remove the recorder sensor cover (2 screws) of the inside (the right back front) of the freezer. (Fig. 2)

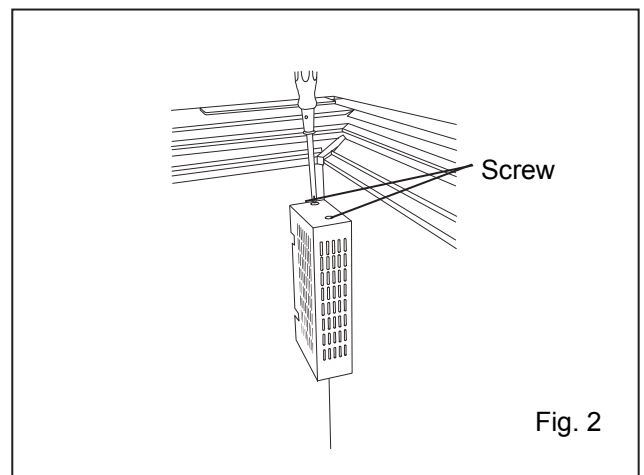

3. Pass a recorder sensor through the inside of the freezer, and use the clip of the recorder sensor cover, and fix a recorder sensor with a screw. Seal the recorder sensor hole with a silicon caulking. (Fig. 3)

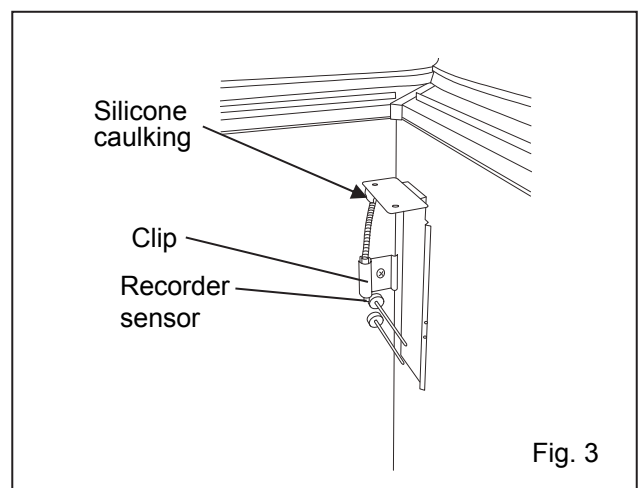

TEMPERATURE RECORDER (OPTION)

4. Pass a recorder sensor through the inside of the freezer in the hole (It is blocked with the rubber stopper and the insulation in this hole. Remove it first.) for the recorder sensor. (Fig. 4)

5. Fix a recorder sensor cover with 2 screws. (Fig. 2)

6. Bind the extra lead wire of the sensor with a nylon clip on the back of the temperature recorder. (Fig. 4)

7. As shown in the Fig. 5, insert the temperature recorder by using the recorder fixing(MDF-S30150) and temperature recorder fitting to the mounting space and fix it to the front side of the front panel. Fix with four screws.

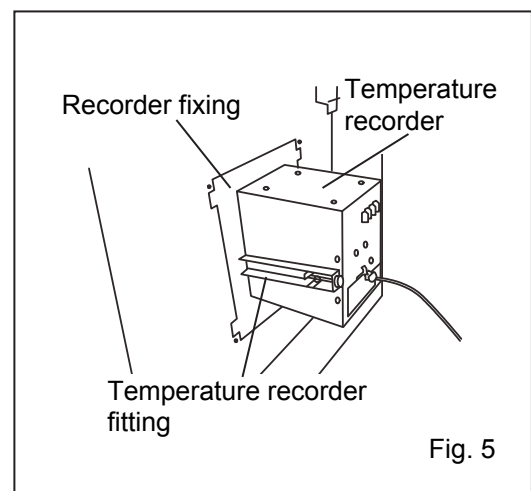
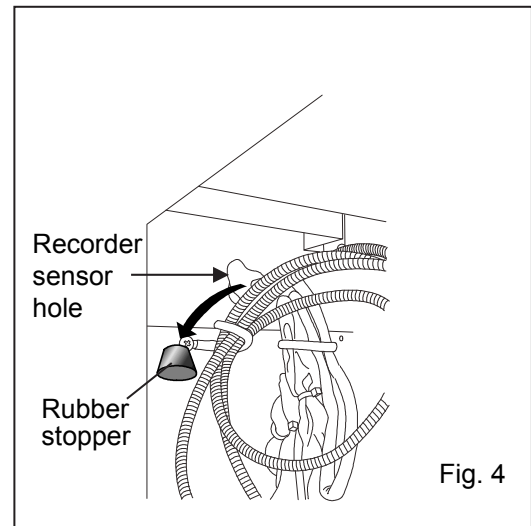

8. Check that setup temperature is the same as chamber temperature of the freezer.

After that, record indication temperature of the recorder and the freezer internal temperature indication of the control panel. Adjust it to freezer internal indication temperature with a zero adjustable screw of the recorder when indication temperature of the recorder and freezer internal temperature indication deviate.

MOUNTING OF INTERFACE BOARD (OPTION)

By installing an interface board (MTR-480), the log data can be transmitted to a PC. The mounting procedure is as follows:

1. Remove 4 screws of the communication box cover. (Fig. 1)
2. Provide an interface board (MTR-480) code from the fitting hole. (Fig. 2)
3. Refer to the instruction manual attached to the interface board for the setup of the TERMINATOR switch of the interface board (MTR-480). (Fig. 3)
4. Connect to the connector side (the back side of the interface board) of a communication cable (RS-232C or RS-485) to use for the interface board (MTR-480). (Fig. 5 is a connection example to use RS-232C.) (Fig. 4 and 5)
5. Fix an interface board (MTR-480) on the control panel with 4 screws. (Fig. 6)

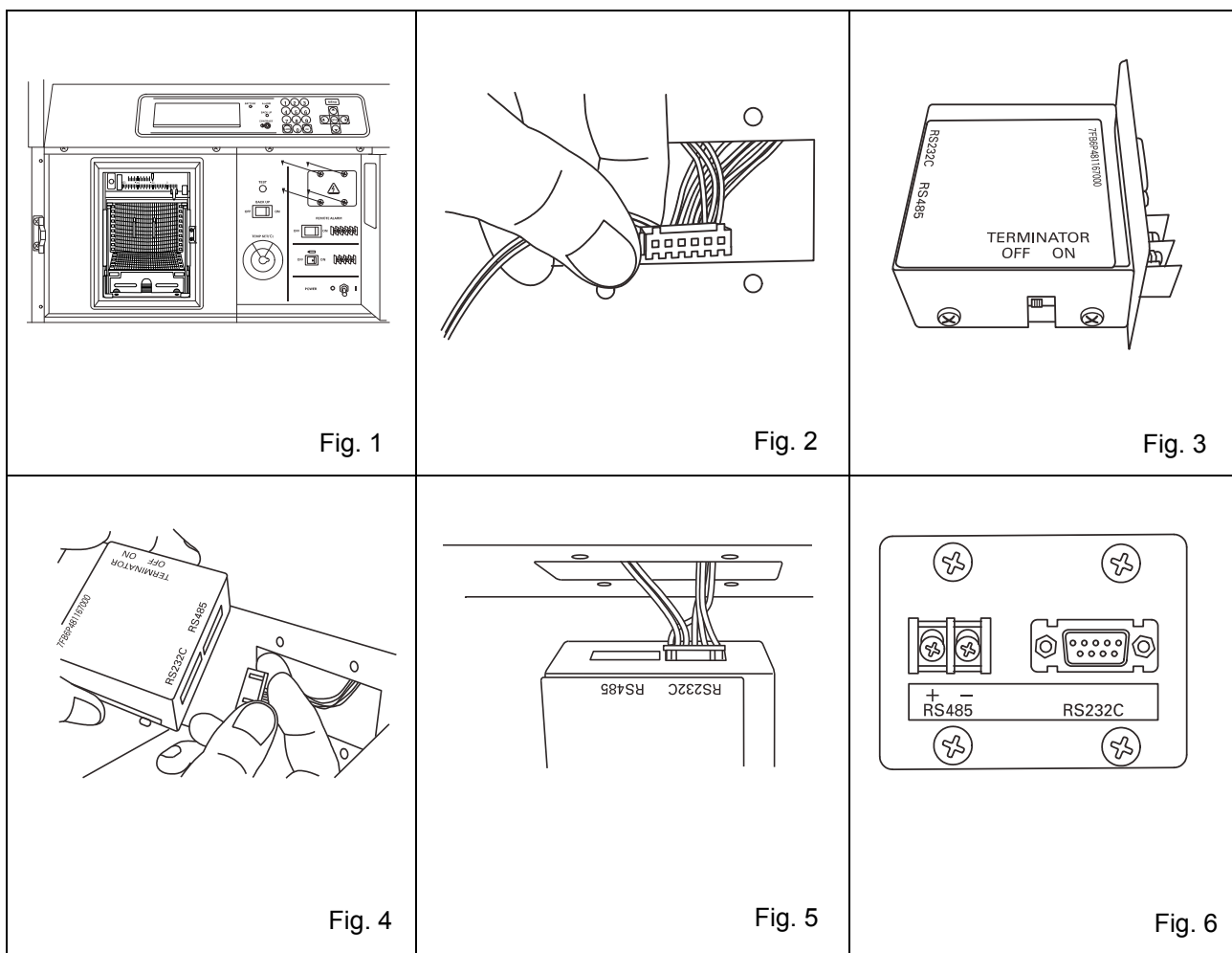

◆ When a data transmitting function to the personal computer is done, an interface board MTR-480 (option goods) and communication cable of 9 pin Dsub cross type for RS232C are necessary.

SPECIFICATIONS

Product name	Ultra-Low Temperature Freezer MDF-C2156VAN	Ultra-Low Temperature Freezer MDF-C2156VANC
External dimensions	W1730 mm x D765 mm x H1010 mm	
Internal dimensions	W760 mm x D495 mm x H615 mm	
Effective capacity	231 L	
Exterior	Painted steel	
Interior	Aluminum plate	
Outer door	Painted steel	
Inner door	Rigid polyurethane foamed-in place	
Access port	40 mm diameter, 1 locations (in the side table)	
Insulation	Vacuum insulation panel + Rigid polyurethane foamed-in place	
Compressor	High stage side; Hermetic type, Output; 1100 W Low stage side; Hermetic type, Output; 1100 W	
Evaporator	High stage side; Cascade condenser type, Low stage side; Tube on sheet type	
Condenser	High stage side; Fin and tube type, Low stage side; Auto cascade type	
Refrigerant	High stage side; R-407D, Low stage side; HFC mixed refrigerant	
Temperature controller	Microcomputer control system	
Temperature display	Digital display	
Thermal sensor	Platinum resistance (Pt 1000 Ω)	
Alarm	High temp. alarm, Low temp. alarm, Power failure alarm, Door alarm Filter check	
Remote alarm contact	Allowable contact capacity: DC 30 V, 2 A	
Battery	Lead storage battery, DC 6 V, 7.2 Ah x 4pcs, Auto-recharge	
Accessories	1 set of key, 1 scraper, 1 set connect tube for backup cooling kit	
Weight	318 kg	325 kg
Voltage booster	None	Built-in
Optional component	Temperature recorder + Recorder fixing (MTR-155H + MDF-S30150) Interface board (MTR-480)* Inventory rack (IR-207C, MDF-49SC)	

Note:

- Design or specifications will be subject to change without notice.
- Refer to the updated catalog when ordering an optional component.
- The battery for power failure alarm is an article for consumption. It is recommended that the battery will be replaced about every 3 years. Contact our sales representative or agent at the time of replacement of the battery for recycling.
- Fan motors are expendable supplies. Exchange it for about every 6 years. Contact our sales representative or agent at the time of replacement of the fan motor.
- When a data transmitting function to the personal computer is done, an interface board MTR-480 (option) and communication cable of 9 pin Dsub cross type for RS232C are necessary.

*:For the data acquisition system MTR-5000 user only. Contact our sales representative or agent for purchase.

•

PERFORMANCE

Product name	Ultra-Low Temperature Freezer MDF-C2156VAN/MDF-C2156VANC		
Model No.	MDF-C2156VAN-PB	MDF-C2156VAN-PK MDF-C2156VANC-PA	MDF-C2156VAN-PE
Cooling performance	-150 °C at the center of the chamber (ambient temperature; 30 °C, no load)		
Temperature control range	-125 °C to -150°C (ambient temperature; 30 °C, no load)		
Power source	220 V	220 V	AC 230 V/240 V
Power source	50 Hz	60 Hz	50 Hz
Rated power consumption	1550 W	1700 W	1550 W/1600 W
Noise level	51 dB [A] (background noise; 20 dB)		
Maximum pressure	3085 kPa		

Note :

- Specifications will be subject to change without notice.
- The unit with CE mark complies with EU directives.

CAUTION

Please fill in this form before servicing.
Hand over this form to the service engineer to keep for his and your safety.

Safety check sheet

1. Freezer contents :

- Risk of infection: Yes No
Risk of toxicity: Yes No
Risk from radioactive sources: Yes No

(List all potentially hazardous materials that have been stored in this unit.)

Notes :

2. Contamination of the unit

Unit interior

- No contamination Yes No
Decontaminated Yes No
Contaminated Yes No

Others:

3. Instructions for safe repair/maintenance/disposal of the unit

- a) The unit is safe to work on Yes No
b) There is some danger (see below) Yes No

Procedure to be adhered to in order to reduce safety risk indicated in b) below.

Date :

Signature :

Address, Division :

Telephone :

Product name: Ultra-low temperature freezer	Model: MDF-	Serial number:	Date of installation:
---	----------------	----------------	-----------------------

Please decontaminate the unit yourself before calling the service engineer.

PHC Corporation

1-1-1 Sakada, Oizumi-machi, Ora-gun, Gunma 370-0596, Japan

© PHC Corporation 2018

Printed in Japan
LDCL028100-1
S0418-10418