

IncuSafe

CO₂ Incubator with humidification control function. 165 L



MCO-173AICUVHX-PE



Maintaining optimal humidity for reliable cultures

PHCbi's new CO₂ Incubator features the innovative Active Humidification System, designed to deliver a stable high-humidity environment of 95% ± 5%. By combining natural evaporation with a unique heating-assisted method, the system accelerates humidity recovery after door openings. This reduces the risk of culture medium drying out, ensuring greater environmental stability and protecting the integrity of your cultures.

Smart Hybrid Humidification Control

The system combines heated evaporation, sensor regulated steam generation, and natural evaporation from the humidifying tray to deliver precise, stable humidity. This active-passive approach minimizes edge effect variability and supports demanding applications such as high throughput screening, low volume cultures, and organoid development.

Flexible Humidification Modes

- **Active Humidity Mode**
Operates only the Active Humidity Control System with no water in the humidification tray. It maintains ~80% humidity, adjustable to 90%, and achieves ±1% RH accuracy between 80–90%. This mode reduces condensation risk when measurement or analytical instruments are installed inside the chamber.
- **High-Humidity Mode**
Combines the Active Humidity Control System with natural evaporation from the humidifying tray for stable conditions above 90% RH.

Improved Visibility, Humidity Log Data and Operability

A new 7 inch color LCD touch panel provides intuitive operation with clear icons and improved visibility. Humidity log data and other parameters can be exported via USB, while the interface centralizes notifications, troubleshooting, data logging, and access to the instruction manual, enhancing overall operability.

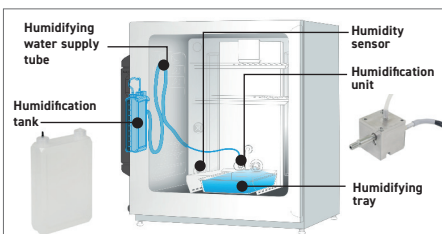

Rapid Humidity Recovery

When humidity drops, water is heated to 140°C, vaporized, and released into the chamber for rapid recovery to the set humidity between 80 and 90%. Recovery is about 50% faster than previous models*1, reducing environmental fluctuations and preventing culture media from drying.

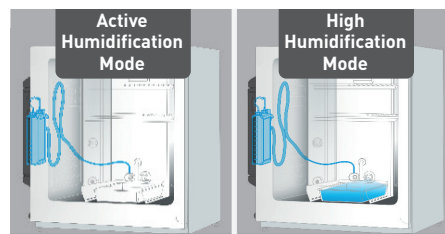

Ethanol Disinfection Function

The Active Humidification System incorporates a semi automatic ethanol disinfection sequence for both the steam spray unit and the supply tube. This integrated sanitation function enhances operational hygiene, supports reliable long term performance, and reduces maintenance requirements and associated running costs.



Contamination prevention and intervention

- inCu-saFe Interior - Copper-enriched stainless steel combines durability with germicidal protection.
- SafeCell UV-LED lamp - Decontaminates air and water without harming cell cultures.
- Rapid H₂O₂ Decontamination - Vaporized hydrogen peroxide and UV-LED lamp clean the chamber in under 3 hours, achieving >6-log contaminant reduction.

CO₂ Incubator with humidification control function



Direct Heat and Air Jacket System

Achieves accurate, uniform, and highly responsive temperature control within the chamber, providing exceptional uniformity and rapid recovery after door-openings.

Dual IR CO₂ Sensor

The incubator's Dual IR sensor and P.I.D control enables ultra-fast CO₂ recovery, without overshoot, even following multiple door-openings.

Active Background Decontamination

The exclusive inCu-saFe copper-enriched stainless steel alloy interior offers the germicidal properties of copper and the durability of stainless steel. The isolated, SafeCell UV-LED lamp decontaminates circulating air and water in the humidifying pan, without harming cultured cells.

Time-Saving H₂O₂ Decontamination

The high-speed decontamination system uses vaporised hydrogen peroxide and UV light. It cleans the chamber of the incubator safely in less than three hours, achieving a minimal 6- log reduction of major contaminants.

Condensation Management

The 'dew stick'—controlled by Peltier technology—condenses water on its surface, which then drips into the humidifying pan, preventing unwanted condensation in the chamber and possible contamination.

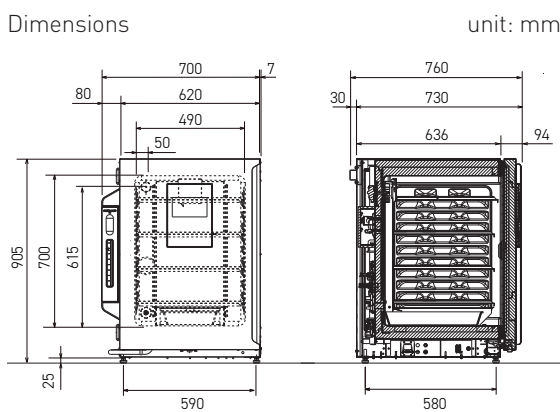

Model Number		MCO-173AICUVHX-PE
Dimensions		
External dimensions (WxDxH) ¹⁾	mm	700 x 730 x 905
Internal dimensions (WxDxH)	mm	490 x 523 x 665
Volume	litres	165
Net weight (approx)	kg	79
Performance		
Temperature control range	°C	Ambient temperature plus 5°C to max. 50°C ²⁾ (ambient temperature: 5°C to 35°C)
Temperature uniformity ³⁾	°C	±0.25
CO ₂ control range & fluctuation ³⁾	No RH	0 to 20, ±0.15
Humidity level & fluctuation	%RH	95, ±5
Control		
Temperature sensor		PID control method
CO ₂ sensor		PID control method
Display		WVGA full color LCD touchpanel
Construction		
Exterior material		Painted steel
Interior material		Stainless steel copper-enriched alloy
Insulation material		Expandable polyacrylonitrile/styrene beads
Heating method		DHA method (heater jacket + air jacket)
Humidification method		1. [80%RH to 90%RH] Heater-type forced evaporation 2. [90% RH or higher] Heater-type forced evaporation + humidification tray natural evaporation
Sterilisation method		H ₂ O ₂ internal decontamination
Outer door	qty	1, Field-reversible
Electric door lock with password		Standard
Inner door	qty	1 (Tempered glass)
Shelves		4 x Stainless steel copper-enriched alloy
Shelf dimensions (W x D x H)	mm	470 x 450 x 12
Max. load per shelf	kg	7
Access port	qty	1
Access port position		back, top left
Access port diameter	Ø mm	30
Alarms		
		(R = Remote Alarm, V = Visual Alarm, B = Buzzer Alarm)
Power failure		V-B-R
Temperature deviation		V-B-R
High temperature		V-B-R
CO ₂ deviation		V-B-R
Door open		V-B
Electrical and noise level		
Power supply	V	220 - 240
Frequency	Hz	50/60
Noise level ⁴⁾	dB	25 (A scale)
Options		
Tray (same as standard accessory)		MCO-170ST-PW
Half Tray		MCO-25ST-PW
CO ₂ gas automatic switch		MCO-21GCP-PW
Gas Pressure Regulator		MCO-010R-PW
H ₂ O ₂ generator		MCO-50HP-PW
H ₂ O ₂ decontamination reagent		MCO-20H2O2-PW
Roller Base		MCO-170RB-PW
Double-stacking Plate		MCO-170SB-PW / MCO-230SB-PW
Double-stacking Bracket ⁵⁾		MCO-170PS-PW
Optional communication systems ⁶⁾		
Mod-bus interface board		MTR-MOdB1-PW
OPC-UA interface board		MTR-OPC1-PW
Interface Board (4-20mA)		Standard

Appearance and specifications are subject to change without notice.

PHC Europe

A Member of PHC Group

Eikdonk 1 | 4825 AZ Breda | Netherlands
T: +31 (0) 76 543 3833

www.phcd.com/eu/biomedical

* 0123 Available in these countries as a Class IIa MDR Medical Device.
Austria, Belgium, Cyprus, France, Germany, Ireland, Italy, Liechtenstein, Luxemburg, Malta, the Netherlands, Poland, Spain, Switzerland and the United Kingdom.

Available as equipment for laboratory use in:
EEA countries, Switzerland, the United Kingdom and Turkey.

Notes:

- 1) Exterior dimensions of main cabinet only, excluding handle and other external projections.
- 2) When set temperature is 37°C, ambient temperature must be 32°C or lower. Regardless of ambient temperature, the maximum of temperature control range is always 50°C.
- 3) Ambient temperature 23°C, setting 37°C, CO₂ 5%, no load.
- 4) Nominal value.
- 5) If stacking two incubators, make sure the double-stacking dedicated securing hardware and spacer are used.
- 6) Can only be fitted with one communications interface.

