

**TectoCell Standard Plus 80 Cold rooms and deep-freezing rooms**  
**TectoCell Standard Plus 100 Cold rooms and deep-freezing rooms**  
**TectoCell Standard Plus 120 Deep-freezing rooms**  
**TectoCell Standard Plus 150 Deep-freezing rooms**



## Contents

<b>1. Technical Data</b>	3
1.1 Dimensions	3
1.2 Thermal Insulation	3
<b>2. Special Features</b>	3
<b>3. General Information</b>	4
<b>4. Room Surfaces</b>	4
<b>5. Hard Polyurethane Foam</b>	5
<b>6. Connections and Joints of the Room Elements</b>	5
<b>7. Room Installation</b>	6
<b>8. Floor Elements</b>	7
8.1 Cold rooms with insulated floor elements	7
8.2 Joint-free stainless steel floors	7
8.3 Stainless steel floor surface (with slip resistance classes)	7
8.4 T0 floor without radius to the room wall in standard rooms	8
8.5 T13 Tub stainless steel floor with radius to the room walls	8
8.6 Standard cold room without floor elements	8
8.7 Suggestions for special design of building floors (e.g., with electric floor heating)	8
<b>9. Cold Room Doors</b>	9
9.1 Description	9
9.2 Positioning of door	9
9.3 Mounted outside in the door frame	9
9.4 Fitted inside on the door frame	9
9.5 Door dimensions	9
<b>10. Installation Dimensions of the Room Door</b>	10
10.1 Door frame instead of a wall medial element	10
10.2 Corner door frame instead of a wall end element, left or right	10
10.3 Dimensions of pivot range of room door leaf	10
<b>11. Ceiling Elements</b>	11
<b>12. Combination Rooms</b>	11
<b>13. In-stock Cold Rooms and Deep-freezing Rooms</b>	12
<b>14. Tender Texts</b>	13
14.1 Features	13
14.2 Connecting the room elements	13
14.3 Room surfaces (except for floor interior top side)	13
14.4 Floor elements – Floor top side	13
14.5 Rooms without floor elements	13
14.6 Cold room doors	14
14.7 Combination rooms	14
14.8 Delivery and installation	14
14.9 Shelf systems and refrigeration units, see Cold Portfolio	14
<b>15. Tender Texts – Specification</b>	15

# 1. Technical Data

## 1.1 Dimensions

Room model	TectoCell Standard Plus 80	TectoCell Standard Plus 100	TectoCell Standard Plus 120	TectoCell Standard Plus 150
Wall thickness	80 mm	100 mm	120 mm	150 mm
External height with floor (Standard floor T0)	2110 mm	2150 mm	2190 mm	2250 mm
	2410 mm	2450 mm	2490 mm	2550 mm
	2710 mm	2750 mm	2790 mm	2850 mm
External height without floor	2045 mm	2065 mm	2085 mm	2115 mm
	2345 mm	2365 mm	2385 mm	2415 mm
	2645 mm	2665 mm	2685 mm	2715 mm
Standard cold room sizes*				
Width	1500 – 6000 mm	1500 – 6000 mm	1500 – 6000 mm	1500 – 6000 mm
Depth	1200 – 6000 mm	1200 – 6000 mm	1200 – 6000 mm	1200 – 6000 mm

\* 300 mm and 100 mm grid. Customisation and larger cold room sizes on request.

## 1.2 Thermal insulation

Wall thickness	80 mm	100 mm	120 mm	150 mm
Recommended temperature difference As per VDI 2055 ( $\Delta T$ in Kelvin)	38K	45 K	56 K	70 K
Temperature range	-20°C to +60°C	-25°C to +60°C	-30°C to +60°C	-50°C to +60°C
U-value as per DIN EN 13165 <sup>1)</sup>	0.25 W/m <sup>2</sup> K	0.20 W/m <sup>2</sup> K	0.17 W/m <sup>2</sup> K	0.14 W/m <sup>2</sup> K
Foam density	40 kg/m <sup>3</sup>			
Building material class	As per DIN EN 13501-1, classification as per F or optional B-S3, d0			
Insulation	Polyurethane – hard foam with cyclopentane/isopentane blend			

<sup>1)</sup> does not apply to floor elements

# 2. Special Features

- Quick and easy installation thanks to the tongue and groove system with self-centring eccentric cams
- Easy expansion and reassembly thanks to joints that require neither glue nor silicone
- Viessmann joint-free and continuously underlapped stainless steel floors
- Non-slip floor pressing in several versions
- Fully hygienic wall radii
- High hygienic standard with anti-microbial SmartProtec® surfaces
- Optionally available with a floor radius in the special version for easy cleaning with optimal hygiene
- Joint-free overlapping of the walls prevents the formation of dirt and water
- Comprehensive range of accessories
- Perfectly tailored system technology with optionally available refrigeration units and shelving systems
- High standard of packaging for protecting goods and transporting them safely

- Rooms in the plus range or with alternative floor structure optionally without floor elements and with mounting frames for the room walls:

Material:	U-profile Plastic	U-profile Stainless steel
Wall thickness (mm)	80 100	80 (optional) 100 (optional) 120 150

- Cold room hinge door, interior lighting, thermometer and pressure compensation valve Fittings on the exterior integrated in a control panel
- Available as combination rooms with partition walls in 50 mm grid for operating with different temperatures

### 3. General Information

- Viessmann cold room elements are precisely and homogeneously manufactured with cyclopentane/isopentane blend foamed polyurethane. They have low thermal conductivity values, high compressive strength and great stability.
- The element connections with a tongue and groove system and corrosion-protected eccentric cams enable fast assembly and disassembly.
- The elements of the room ceilings are not dimensioned for additional forces (snow load, rain water, wind pressure, etc.). During on-site installation, adequate reinforcement or static protection should be ensured before inspection, when a ceiling refrigeration unit is installed, or for other structures such as meat hangers, tubular tracks, etc.

### 4. Room Surfaces:

The room elements are available with the following facings:

#### STA=

Viessmann standard white powder coating, sheet steel galvanized with Viessmann SmartProtect® anti-microbial powder coating.

Colour white, similar to RAL 9016.

No transfer and spreading of potentially hazardous microorganisms due to the physical properties of the surface. It offers no habitat for parasites and causes bacteria and fungi to die off.

#### EST=

Austenitic stainless steel

(Material no. 1.4301) – polished or brushed special versions

Other materials are available on request.

#### Facing combinations

	Outer panel	Inner panel
Standard rooms	STA	STA
Special version	STA EST	

## 5. Hard Polyurethane Foam

Viessmann cold rooms are insulated effectively with cyclopentane/isopentane blend foamed polyurethane and are tight due to the tongue and groove system. The cyclopentane/isopentane blend enables precise foaming of the room elements and easy installation.

## 6. Connections and Joints of the Room Elements

The sandwich cold room panels (floors, walls, ceilings) are connected using a self-centring tongue and groove system. Eccentric cam locks with plastic housing and corrosion-resistant clamping hooks are foamed into the elements. The cam locks should be worked from the inside; the room does not need to be accessible from the outside during installation.

The joints of the TectoCell Standard Plus 80, 100, 120, and 150 wall elements are executed with tongue and groove and interstitial PE sealing. The panels come with joint-free Tecto overlapping. The corners of the wall panels are finished with a radius.

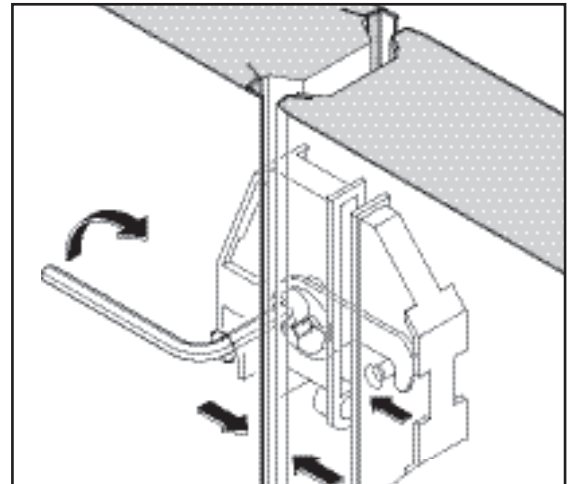

Walls with foamed cam lock connection

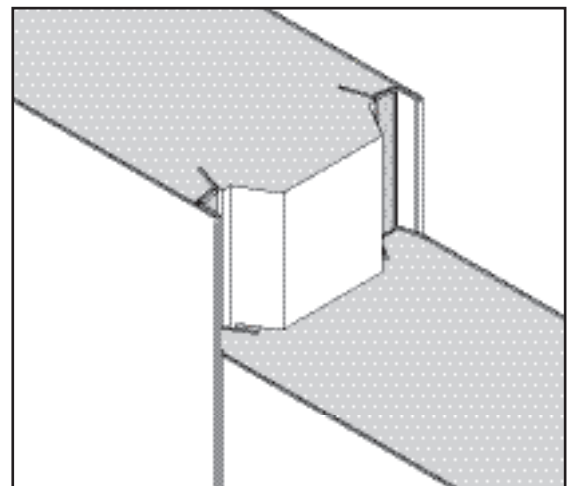

Walls – element joint overlapping

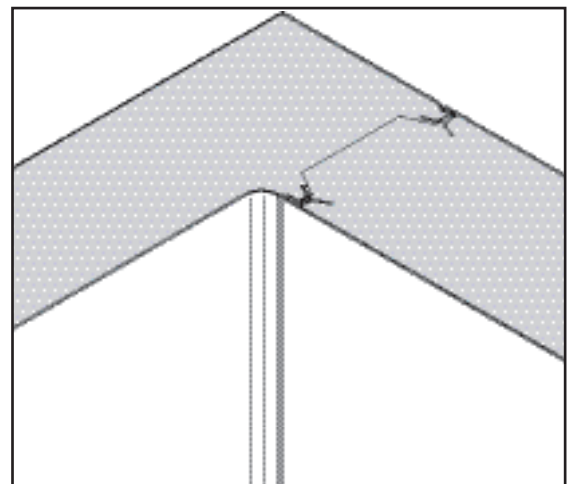

Walls – corners with radius

## 7. Room Installation:

The room should be set up in a well aerated and ventilated space so that the heat generated by the refrigeration unit is safely discharged and a heating up of the installation area is avoided. The run time of the refrigeration unit is thereby reduced and with it the electricity costs, and the refrigeration unit is rested. The distance of the cold room from the building wall and the open space above the room must be at least 50 mm with a cold room temperature in the plus range and 100 mm with a cold room temperature in the minus range. A corresponding installation height should be additionally calculated for floor prop designs. Before beginning the installation, the installation space measurement should be rechecked.

It must be ensured that the floor elements are laid only on a level and smooth floor (as per VOB specifications). For an uneven and non-level floor (e.g., concrete), the dimensional difference should be compensated by underlays.

Cold and deep-freeze rooms that are operated in the temperature range below  $-5^{\circ}\text{C}$  must be installed on base plates as protection against freezing underneath the room. Electric floor heating can also be used instead of the base plates.

### Outdoor installation

For outdoor installation, it should be ensured by local and on-site construction measures (self-supporting roofing and side walls) that the cold room is not exposed to weather impacts (snow load, rainwater, wind pressure, etc.). These precautions must be completed before installation.

When cold rooms are installed outdoors, discoloration of the paint may occur due to UV exposure.

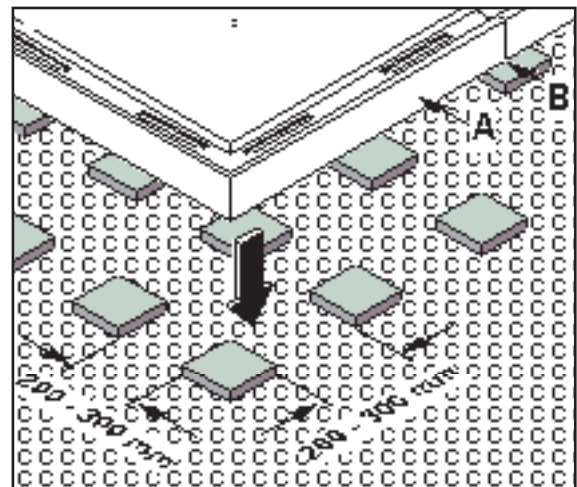

Room installation – Installation on floor plates

## 8. Floor Elements

T0 = standard floor  
 T13 = tub floor  
 Room without floor elements

### 8.1 Cold rooms with insulated floor elements

Floor structure:

- Austenitic stainless steel sheet, material no. 1.4301
- Pressure distribution plate
- PU hard foam with tongue and groove
- Outer panel

Features:

- Joints of the floor elements are seamless, underlapped continuously and interlocking and riveted during installation
- Stainless steel surfaces have multi-directional non-slip properties (R11) due to a special Viessmann pressing process
- Permissible loads of the room floors:

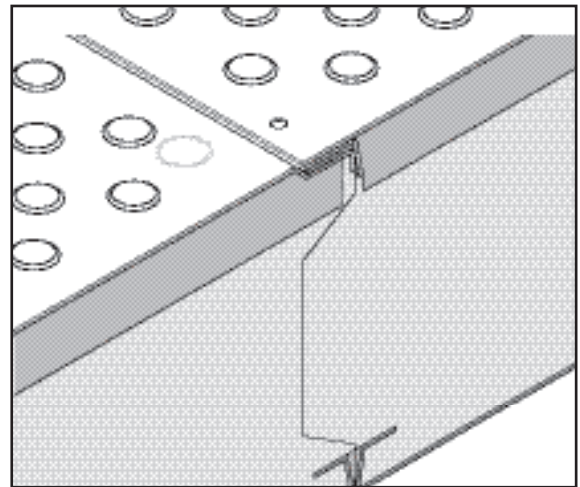

Underlapping of the stainless steel floors

Loading Class	Wheel	Wheel Load (N <sup>**</sup> )		Surface Load in N/m <sup>2</sup>
		1 - 4 cm <sup>2</sup>	> 4 cm <sup>2</sup>	
1	Rubber	400	1.600	30.000
2	PU-/Rubber	750	3.000	40.000
3	PU-/Rubber	1.000	4.000	50.000
4*	PU-/Rubber	1.250	5.000	50.000

\* Loading Class 4) Special for 5.000N floor with underlapping.  
 Extended approval for 6.000N possible after internal check.

\*\* 10N ≈ 1Kg

#### Floor elements – Special version of stainless steel cold room floors:

- Other slip resistant classes
- Other loads

### 8.2 Joint-free stainless steel floors

For the **stainless steel floors**, the joint between the floor elements is seamless, underlapped continuously with a glued-on, high quality sealant.

The underlapping is riveted during installation, so that penetration by moisture into the room floor and with it germ formation can be avoided.

### 8.3 Stainless steel floor surface (with slip resistant classes)

#### Greater safety due to slip-resistant stainless steel floor surface

Our stainless steel room floors have multi-directional non-slip properties (R11) due to the special Viessmann pressing process. Lower or higher slip-resistant classes are also available (e.g., R10, R12).

## 8. Floor Elements

### 8.4 T0 floor for standard cold rooms

Stainless steel floor cone-pressed, slip resistance class R11, drivable up to 1000 N per rubber wheel.

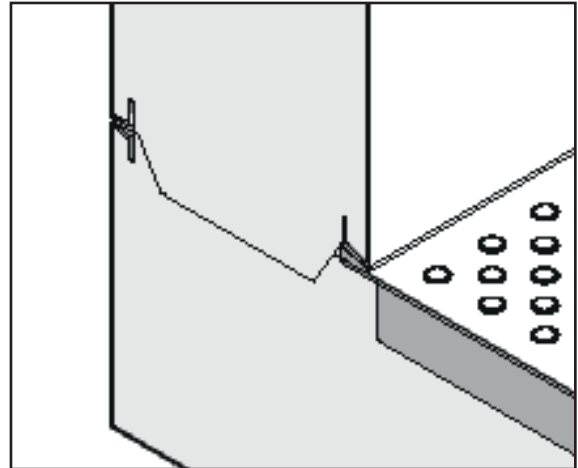

Connection T0 stainless steel floor – room wall without radius

### 8.5 T13 Tub stainless steel floor with radius to the cold room walls (special version)

With the optional special version, the cold and deep-freezing rooms are equipped with a tub-shaped stainless steel floor, which is executed with a shaped radius at the junction with the walls of the room. The corners of the floor are also rounded. Floor and radii are composed of stainless steel – a durable and hygienic design as opposed to glued-on plastic radii.

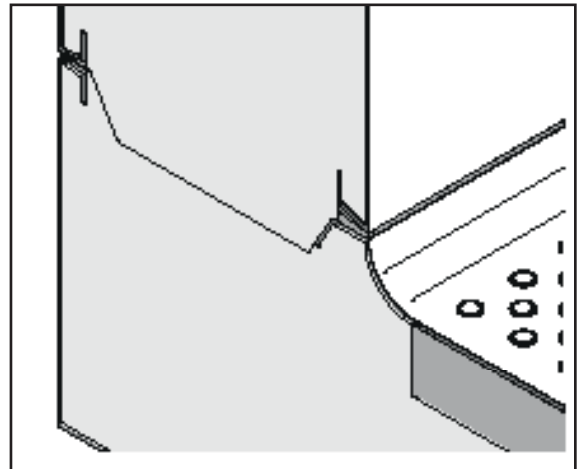

Connection T13 tub stainless steel floor – room wall with radius (special version)

### 8.6 Standard cold room without floor elements

The cold room can be installed without floor elements in rooms in the plus temperature range or with alternative floor structures. The wall elements are placed in U-profiles for mounting, riveted or screwed together, and screwed to the floor of the installation room.

Material	U-profile Plastic	U-profile Stainless steel
Wall thickness (mm)	80 100	80 (optional) 100 (optional) 120 150

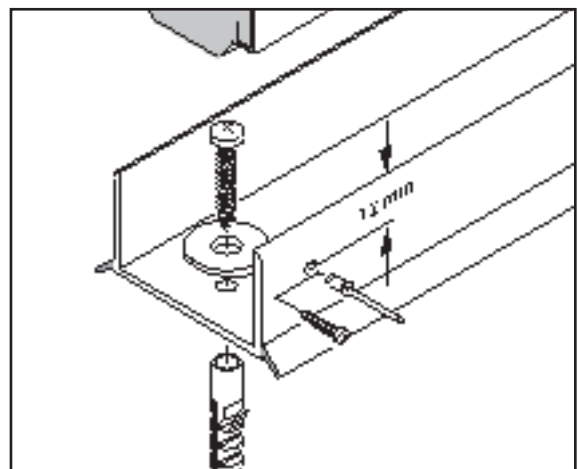

Attaching the mounting frame

### 8.7 Suggestions for special execution of building floors (e.g., with electric floor heating)

On request we will send you our data sheet no. 00570022 with suggestions for special execution of building floors for specific operational requirements.

## 9. Cold Room Doors

### 9.1 Description:

- An outward opening single leaf overlying hinge door with magnetic seal as well as removable, upward, and three-dimensionally adjustable door hinges.
- Rotary lever lock with spring-loaded latch and cylinder lock as well as emergency-opening device for opening the locked door from the inside.
- Door hinged on right or left.
- Door leaf foamed with polyurethane hard foam with cyclopentane/isopentane blend.
- Threshold cover plate made of stainless steel for room with thermally insulated floor elements.

### 9.2 Positioning of door:

- The door can be positioned at any location on the room wall within the grid.
- The minimum distance of the door opening to the room corner is at least 150 mm.

### 9.3 Installed outside in the door frame:

- Door frame heating (see table)
- Control panel with thermometer, light switch and pressure compensation valve with or without heating (IPX4).
- The pressure compensation valve is designed for a refrigerating capacity of the refrigerating unit up to a maximum of 5 kW. In the case of a higher refrigerating capacity, a larger pressure compensation valve or several of them must be installed.

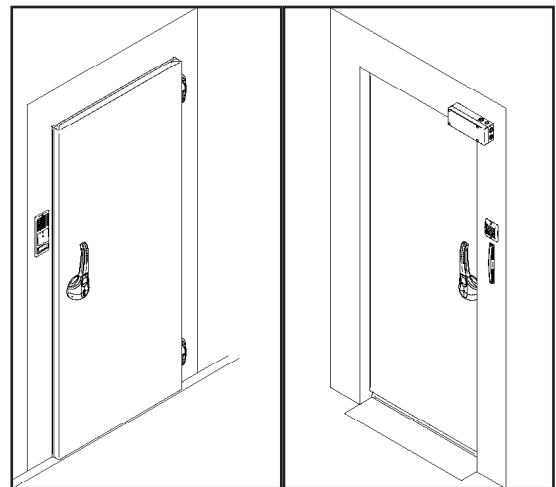

### 9.4 Fitted inside on the door frame:

- Door frame LED light (IP 44) and junction box (IP 66). All cables are installed and wired in the door element

### 9.5 Door – dimensions<sup>1)</sup>

Wall thickness	80		100		120	150
External height with floor (mm)	2110	2410 2710*	2150	2450 2750*	2490	**
External height without floor (mm)	2045	2345 2645	2065	2365 2665	**	**
Clear width x clearance height <sup>2)</sup>	600 x 1800 800 x 1800 1000 x 1800 1200 x 1800	600 x 2000 800 x 2000 1000 x 2000 1200 x 2000	600 x 1800 800 x 1800 1000 x 1800 1200 x 1800	600 x 2000 800 x 2000 1000 x 2000 1200 x 1800	600 x 2000 800 x 2000 1000 x 2000 1200 x 2000	**
Door frame heating	*		with		with	**

\* not in stock

\*\* on request

<sup>1)</sup> Workplace regulations in their currently valid version must be taken into consideration

<sup>2)</sup> For cold rooms without a floor, the clearance height is increased by 15 mm.

## 10. Installation Dimensions of the Room Door

### 10.1 Door frame instead of a wall medial element

The width of the door frame depends on the clear width of the door (see table). The door frame can be positioned 300 mm at any location of the room walls in the grid. A distance from the room corner of at least 300 mm to the left or right is required (see drawing, dimension B and C). D and E = a minimum distance of 450 mm.

Clear width Door clear width (mm)	Distance A (mm)	Width Door frame F (mm)
600	150	900
800	200	1200
1000	250	1500

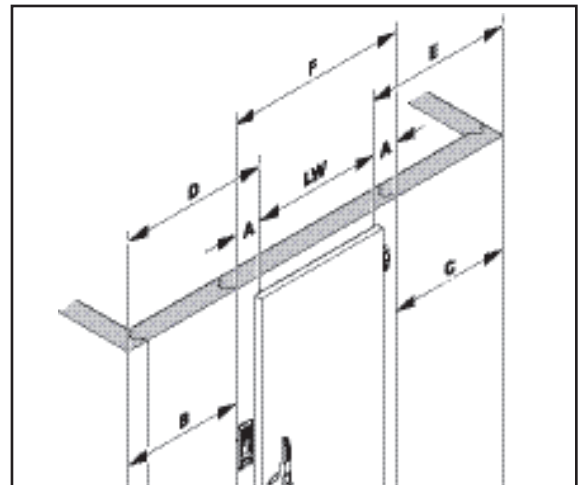

Middle door frame element

### 10.2 Corner door frame instead of a wall end element left or right

For a corner door frame, the arrangement of the fittings depends on the side of the corner connection and the selected door hinge.

### 10.3 Dimensions of pivot range of room door leaf

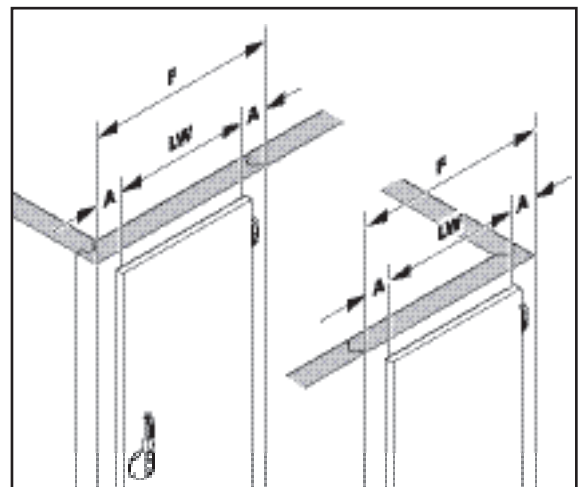
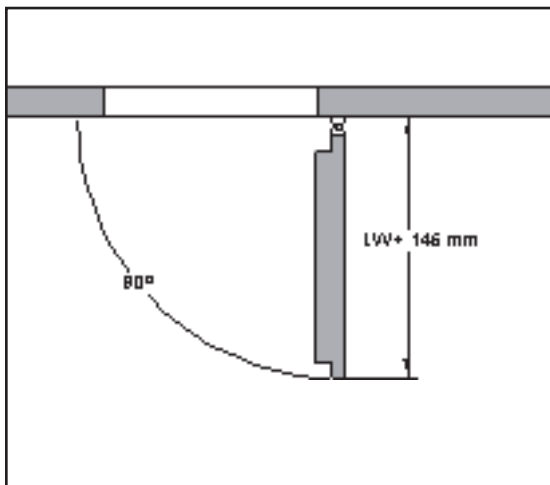

Corner door frame element

## 11. Ceiling Elements

The elements of the room ceilings are not dimensioned for additional forces (snow load, rain water, wind pressure, etc.). During on-site installation, adequate reinforcement or static protection should be ensured before inspection, when a ceiling refrigeration unit is installed, or for other structures such as meat hangers, tubular tracks, etc.

The maximum self-supporting span width of ceiling elements is 6 m.

Supported or suspended constructions are required for larger span widths or divided ceiling elements (special models).

- Self-supporting supports, consisting of two steel C-profiles (up to 6.9 m ceiling span width)
- Suspended supports, consisting of two steel C-profiles (over 6.9 m ceiling span width with attachment to concrete ceiling or on-site steel construction, etc.)

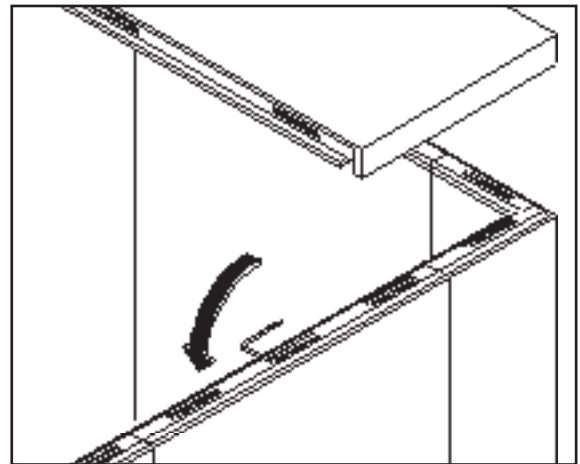

Ceiling installation

## 12. Combination rooms

With Tecto combination rooms, one or more partition walls are built in. Floor, walls, and ceilings can be optionally provided with tongue and groove connections for this purpose, or the walls can be installed without a tongue and groove system. Attachment is made by means of a mounting bracket.

See adjoining diagrams for execution of Tecto combination rooms – cold rooms and deep freezing rooms (partition walls and doors).

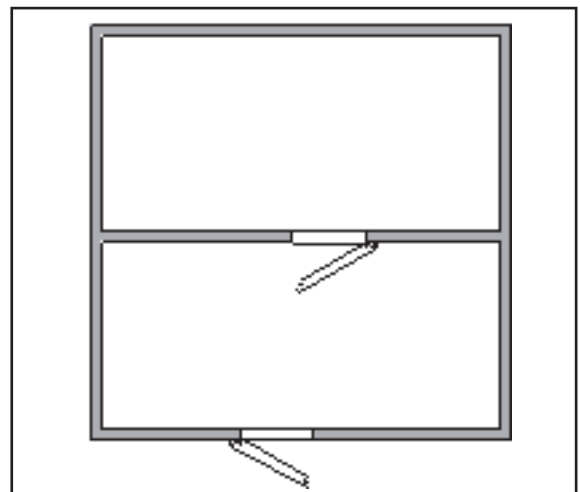

Example of combination room

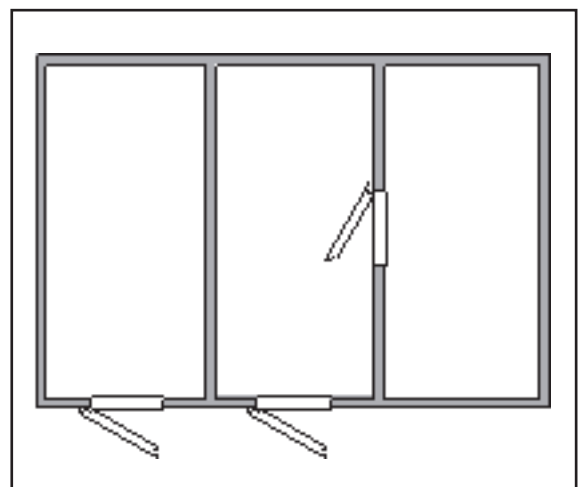

Example of combination room

### 13. In-stock Cold Rooms and Deep-freezing Rooms

In-stock cold rooms and deep-freezing rooms:

Room model	TectoCell Standard Plus 80	TectoCell Standard Plus 100
Exterior height with standard floor T0	2110 mm 2410 mm	2150 mm 2450 mm
External height without floor	2045 mm 2345 mm	2065 mm 2365 mm
Width	1500 – 3600 mm	1500 – 3600 mm
Depth	From 1200 mm in grid of 300 mm	
Lead time	ex-warehouse	

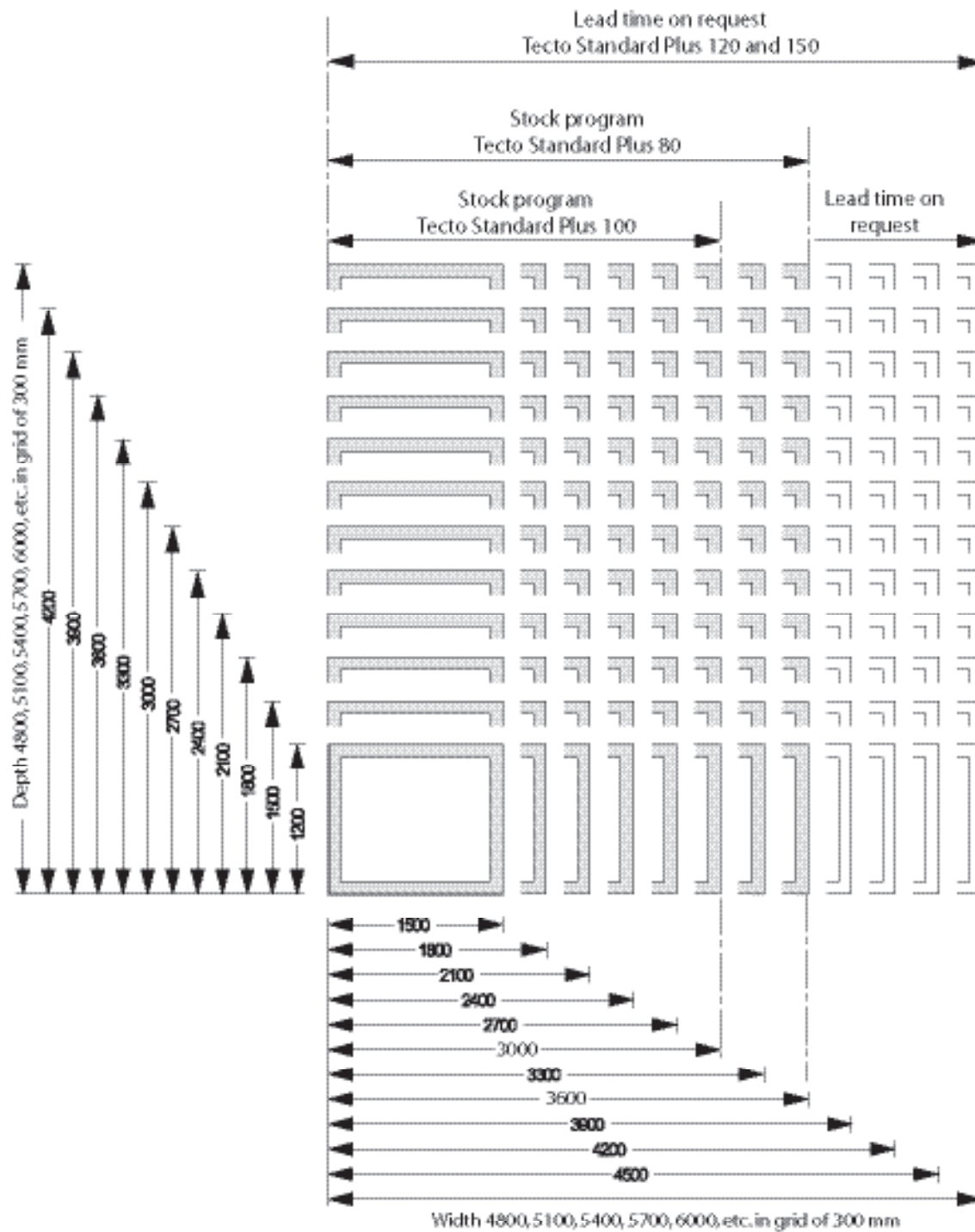

## 14. Tender Texts

### 14.1 Features:

- Thermal insulation foamed with polyurethane hard foam with
- cyclopentane/isopentane blend (closed cell).
- Foam density of 40 kg/m<sup>3</sup>.
- Heat conductivity group 025 as per DIN 4108.
- Building material class as per DIN 4102, classification as per B3.

Wall thickness (mm)	80	100	120	150
Recommended temperature difference As per VDI 2055 $\Delta T =$ (Kelvin)	38 K	45 K	56 K	70 K
U-value in accordance with DIN EN 13165 <sup>1)</sup>	0.25	0.20	0.17	0.14

- Thermal bridge-free cold room elements in a sandwich construction – sturdy, self-supporting, and true to size.
- Maximum self-supporting span width of ceiling elements: 6000 mm
- T0 floor, Tecto overlapping wall element joint and radii in the inner corners of the walls.
- Optional special version with T13 floor (floor radius)
- Wall and ceiling elements as well as doors are wood-free.
- The joints of the wall elements are executed with a tongue and groove system and an interstitial PE sealant.

### 14.2 Connecting the room elements

The room elements (floors, walls, ceilings) are connected using a self-centring tongue and groove system. Eccentric cam locks with plastic housing and corrosion-resistant clamping hooks are foamed into the elements.

### 14.3 Room surfaces (except for floor interior top side)

#### STA

Viessmann standard white powder coating, sheet steel galvanized with Viessmann SmartProtec® anti-microbial powder coating. Colour white, similar to RAL 9016.

No transfer or spreading of potential hazardous microorganisms thanks to the physical properties of the surface. It offers no habitat for parasites and causes bacteria and fungi to die off.

#### EST

Austenitic stainless steel (material no. 1.4301)  
- special polished or brushed version.

- Note on use:

#### STA

Cold rooms with Viessmann standard white SmartProtec® antimicrobial powder coating are suitable for clean room technology, hospitals, and laboratories as well as for storing sensitive goods (e.g., fruit, vegetables and meat and sausage products). The powder coating is not suitable for wet operation or for moist and aggressive refrigerated products (e.g., fish smokehouses, fermentation interrupters, bakeries and open meat storage.).

#### EST:

Cold rooms with stainless steel floor surfaces are suitable for butcher shops, slaughterhouses, dairies, fermentation interrupters, etc.

### 14.4 Floor elements – floor top side

#### Stainless steel floor

(Material no. 1.4301 – austenitic stainless steel).

- Joints of the floor elements are seamless, underlapped continuously and interlocking and riveted during installation.
- Stainless steel surfaces have multi-directional non-slip properties (R11) due to a special pressing process.
- Permissible loads of the cold room floors:

Loading Class	Wheel	Wheel Load (N <sup>**</sup> )		Surface Load in N/m <sup>2</sup>
		1 - 4 cm <sup>2</sup>	> 4 cm <sup>2</sup>	
1	Rubber	400	1.600	30.000
2	PU-/Rubber	750	3.000	40.000
3	PU-/Rubber	1.000	4.000	50.000
4*	PU-/Rubber	1.250	5.000	50.000

- \* Loading Class 4) Special for 5.000N floor with underlapping.  
Extended approval for 6.000N possible after internal check.  
\*\* 10N  $\approx$  1Kg

**Standard floor:** Stainless steel floor cone-pressed, slip resistance class R11, drivable up to 1000 N per rubber wheel.

- **Stainless steel tub floor:** The optional special version is equipped with a tub-shaped stainless steel floor, which is executed with a shaped radius at the transition to the walls of the room. The corners of the stainless steel floor are also rounded (no glued-on plastic radii).

### 14.5 Rooms without floor elements

Mounting frame for the room walls:

Material	U-profile Plastic	U-profile Stainless steel
Wall thickness (mm)	80 100	80 (optional) 100 (optional) 120 150

<sup>1)</sup> does not apply to floor elements

## 14. Tender Texts

### 14.6 Cold room doors

An outward opening single leaf overlying hinge door with magnetic seal as well as removable, upward, and three-dimensionally adjustable door hinges.

Rotary lever door lock with spring-loaded latch and cylinder lock as well as emergency-opening device for opening the locked door from the inside.

Door hinges optionally DIN right  or left 

Door leaf with cyclopentane/isopentane blend foamed polyurethane hard foam.

Threshold cover plate made of stainless steel for room with thermally insulated floor elements.

Installed outside in the door frame: Control panel with thermometer, light switch and pressure compensation valve with or without heating (IP44).

The pressure compensation valve is designed for a refrigerating capacity of the refrigerating unit up to a maximum of 5 kW. In the case of a higher refrigerating capacity, a larger pressure compensation valve or several of them must be installed.

Fitted inside on the door frame: Door frame LED light (IP 44) and junction box (IP 66).  
Adequate lighting as per workplace regulations must be provided on-site as required. All cables are installed and wired in the door element.

### 14.7 Combination rooms

With Tecto combination rooms, one or more partition walls are built in. Floor, walls, and ceilings can be optionally provided with tongue and groove connections for this purpose, or the walls can be installed without a tongue and groove system. Attachment is made by means of a mounting bracket.

### 14.8 Delivery and installation:

Delivery and installation are carried out as per our "Special Conditions for Delivery and Installation of Cold Rooms."

### 14.9 See Cold Portfolio for shelf systems and refrigerating units

## 15. Tender text – Specification

Serial no.	Number	Item	Unit price		Total price										
		<p><b>Viessmann TectoCell Standard Plus Cold Rooms and Deep-freeze Rooms</b></p> <p><b>Overall external dimensions</b>  Width: 0000 mm  Depth: 0000 mm  Height: 0000 mm</p> <p><b>Room model:</b></p> <p><input type="checkbox"/> <b>TectoCell Standard Plus 80</b>  Wall thickness 80 mm (U-value = 0.25 W/m<sup>2</sup>K as per DIN EN 13165)  for temperature differences up to ΔT = 38 K as per DIN 2055  Temperature range -20°C to +60°C</p> <p><input type="checkbox"/> <b>TectoCell Standard Plus 100</b>  Wall thickness 100 mm (U-value = 0.20 W/m<sup>2</sup>K as per DIN EN 13165)  for temperature differences up to ΔT = 45 K as per DIN 2055  Temperature range -25°C to +60°C</p> <p><input type="checkbox"/> <b>TectoCell Standard Plus 120</b>  Wall thickness 120 mm (U-value = 0.17 W/m<sup>2</sup>K as per DIN EN 13165)  for temperature differences up to ΔT = 56 K as per DIN 2055  Temperature range -30°C to +60°C</p> <p><input type="checkbox"/> <b>TectoCell Standard Plus 150</b>  Wall thickness 150 mm (U-value = 0.14 W/m<sup>2</sup>K as per DIN EN 13165)  for temperature differences up to ΔT = 70 K as per DIN 2055  Temperature range -50°C to +60°C</p> <p><b>Wall structure</b>  Elements are connected by a self-centring tongue and groove system and with overlapping joints of the wall elements inside and out, and 10 mm radius in the corners. Foamed, corrosion-protected cam locks for a friction-locked connection of the elements with each other. The eccentric cam locks are firmly foamed in cold bridge-free plastic housings.</p> <p>Surfaces of the wall, ceiling, and door elements are galvanized sheet steel inside and out, powder-coated, white (lead-free) with SmartProtec® anti-microbial powder coating.</p> <p>The Viessmann SmartProtec® powder coating offers active and lasting protection against microorganisms. SmartProtec® naturally prevents potentially hazardous pathogens from colonizing and spreading, which in the end leads to a dying off of bacteria and fungi.</p> <p>SmartProtec® acts both as an antibacterial and antimicrobial agent. Completely harmless to people, SmartProtec® ensures an absolutely safe environment for storing foodstuffs and sensitive products and is an ideal addition to conventional cleaning procedures.</p> <p><b>Wall surfaces:</b></p> <table data-bbox="342 1868 1097 2015"> <tr> <td></td> <td>outer</td> <td>inner</td> </tr> <tr> <td>STA Viessmann standard white powder coating, Sheet steel galvanized with Viessmann SmartProtec® anti-microbial powder coating. Colour white, similar to RAL 9016.</td> <td><input type="checkbox"/></td> <td><input type="checkbox"/></td> </tr> <tr> <td>EST: Austenitic stainless steel</td> <td><input type="checkbox"/></td> <td><input type="checkbox"/></td> </tr> </table> <p style="text-align: right;"><b>Additional cost:</b></p>		outer	inner	STA Viessmann standard white powder coating, Sheet steel galvanized with Viessmann SmartProtec® anti-microbial powder coating. Colour white, similar to RAL 9016.	<input type="checkbox"/>	<input type="checkbox"/>	EST: Austenitic stainless steel	<input type="checkbox"/>	<input type="checkbox"/>				
	outer	inner													
STA Viessmann standard white powder coating, Sheet steel galvanized with Viessmann SmartProtec® anti-microbial powder coating. Colour white, similar to RAL 9016.	<input type="checkbox"/>	<input type="checkbox"/>													
EST: Austenitic stainless steel	<input type="checkbox"/>	<input type="checkbox"/>													

## 15. Tender text – Specification

Serial no.	Number	Item	Unit price	Total price																									
		<p><b>Floor:</b></p> <p><input type="checkbox"/> <b>T0 = standard floor</b>            Floor element interior side stainless steel (1.4301), pressed slip-resistant, glued to waterproof glued chipboard/multiplex board, overlapping at the joint of the floor elements            Permissible load/wheel: 1000 N/wheel            Load area: 4 cm<sup>2</sup>            Permissible surface load: 30,000 N/m<sup>2</sup></p> <p><b>Floor elements – stainless steel surface</b></p> <table border="0"> <tr> <td></td> <td>Wheel &lt; 1cm<sup>2</sup></td> <td>Wheel &lt; 4cm<sup>2</sup></td> <td>Area 1m<sup>2</sup></td> <td></td> </tr> <tr> <td>1.</td> <td>400N</td> <td>1600N</td> <td>30,000N</td> <td></td> </tr> <tr> <td>2.</td> <td>750N</td> <td>3000N</td> <td>40,000N</td> <td><input type="checkbox"/> <b>Additional cost:</b></td> </tr> <tr> <td>3.</td> <td>1000N</td> <td>4000N</td> <td>50,000N</td> <td><input type="checkbox"/> <b>Additional cost:</b></td> </tr> <tr> <td>4.</td> <td>1250N</td> <td>5000N</td> <td>50,000N</td> <td><input type="checkbox"/> <b>Additional cost:</b></td> </tr> </table> <p><input type="checkbox"/> <b>T13 = stainless steel tub floor</b>            Optional special version with tub-shaped stainless steel floor.            Transition to the room walls and corners of the stainless steel floor executed with a shaped radius. <b>Additional cost:</b></p> <p><b>Doors:</b>            An outward-opening single leaf hinge door, overlying, with magnetic frame seal profile and upward-facing, adjustable hinges, compression lever with spring-loaded latch, lockable, inside with emergency opening device, door hinges optionally DIN left or right.            Fitted inside on the door frame: LED light 13 watt (IP44) (corresponds approx. to power of a 100 watt incandescent lamp) and junction box (IP66).            On the outside of the door frame: control panel with integrated light switch, thermometer and pressure compensation valve; in deep-freezing range with door frame heating and heated pressure compensation valve</p> <p>1. Single-leaf hinge door            A) Middle door element                Clear width _____ x _____ mm, facing _____                Door hinge           DIN left <input type="checkbox"/>           DIN right <input type="checkbox"/>            b) Corner door element           left <input type="checkbox"/> right <input type="checkbox"/>           <b>Additional cost:</b>                Clear width _____ x _____ mm, facing _____                Door hinge           DIN left <input type="checkbox"/>           DIN right <input type="checkbox"/> <b>Additional cost:</b></p> <p>2. Double door <b>Additional cost:</b>                Clear width _____ x _____ mm, facing _____                Door hinge           DIN left <input type="checkbox"/>           DIN right <input type="checkbox"/>                Traffic leaf width _____ mm</p> <p><b>Cold room sliding door</b> <b>Additional cost:</b>                DIN left <input type="checkbox"/>           DIN right <input type="checkbox"/>                Clear width _____ x _____ mm, facing _____</p> <p><b>Door frame heating 80</b>           without <input type="checkbox"/> with <input type="checkbox"/> <b>Additional cost:</b></p> <p><b>Swinging door</b></p> <p>1. Single leaf <b>Additional cost:</b>                Clear width _____ x _____ mm, model _____                Door hinge           DIN left <input type="checkbox"/>           DIN right <input type="checkbox"/></p> <p>2. Double <b>Additional cost:</b>                Clear width _____ x _____ mm, model _____</p>		Wheel < 1cm <sup>2</sup>	Wheel < 4cm <sup>2</sup>	Area 1m <sup>2</sup>		1.	400N	1600N	30,000N		2.	750N	3000N	40,000N	<input type="checkbox"/> <b>Additional cost:</b>	3.	1000N	4000N	50,000N	<input type="checkbox"/> <b>Additional cost:</b>	4.	1250N	5000N	50,000N	<input type="checkbox"/> <b>Additional cost:</b>		
	Wheel < 1cm <sup>2</sup>	Wheel < 4cm <sup>2</sup>	Area 1m <sup>2</sup>																										
1.	400N	1600N	30,000N																										
2.	750N	3000N	40,000N	<input type="checkbox"/> <b>Additional cost:</b>																									
3.	1000N	4000N	50,000N	<input type="checkbox"/> <b>Additional cost:</b>																									
4.	1250N	5000N	50,000N	<input type="checkbox"/> <b>Additional cost:</b>																									

## 15. Tender text – Specification

Serial no.	Number	Item	Unit price	Total price
		<p><b>Viewing window</b> <span style="float: right;"><b>Additional cost:</b></span></p> <p>ø 225 mm built into door leaf, without heating <input type="checkbox"/> <span style="float: right;"><b>Order no.</b> _____</span></p> <p>300 x 300 mm heated, built into door leaf <input type="checkbox"/></p> <p><b>Tubular track execution</b> <span style="float: right;"><b>Additional cost:</b></span></p> <p><b>Strip curtain</b></p> <p>For wall installation, clear width _____ x _____ mm <span style="float: right;"><b>Additional cost:</b></span></p> <p>For ceiling installation, clear width _____ x _____ mm <span style="float: right;"><b>Additional cost:</b></span></p> <p><b>Wall element with portholes</b> <span style="float: right;"><b>Additional cost:</b></span></p> <p>Porthole frame heating 80 without <input type="checkbox"/> with <input type="checkbox"/></p> <p>900 mm wide wall element with 1 porthole <input type="checkbox"/> 2 portholes <input type="checkbox"/></p> <p>Middle porthole element <input type="checkbox"/> Corner porthole element <input type="checkbox"/></p> <p>Corner connection left <input type="checkbox"/> right <input type="checkbox"/></p> <p>Clear width of the portholes 620 x 800 mm, facing _____</p> <p>Porthole hinge DIN left <input type="checkbox"/> DIN right <input type="checkbox"/></p> <p><b>Supporting and suspended constructions for larger span widths</b></p> <p><b>Overhead supporting construction</b> <span style="float: right;"><b>Additional cost:</b></span></p> <p>for _____ m span width (room width).</p> <p>Double C-profile self-supporting <input type="checkbox"/></p> <p><b>Overhead suspended construction</b> <span style="float: right;"><b>Additional cost:</b></span></p> <p>Double C-profile suspended <input type="checkbox"/></p> <p>The profile is suspended from a hall ceiling or from a superstructure.</p> <p><b>Accessories</b> <span style="float: right;"><b>Additional cost:</b></span></p> <p><b>Underneath ventilation</b> <span style="float: right;"><b>Order no. 00060001</b></span></p> <p>30 mm thick tiles for underneath ventilation of the room</p> <p><b>Floor cover</b> <span style="float: right;"><b>Order no. 7021 144</b></span></p> <p>For covering rooms with underlying base plates</p> <p><b>Access ramp</b> <span style="float: right;"><b>Order no.</b> _____</span></p> <p>Material: Stainless steel sheet</p> <p>Height _____ mm, length _____ mm, width _____ mm</p> <p>For door with clear width of _____ mm.</p> <p><b>Meat and sausage hanging rails</b> <span style="float: right;"><b>Additional cost:</b></span></p> <p><b>LED cold room/deep-freezing room light</b> <span style="float: right;"><b>Additional cost:</b></span></p> <p>Temperature range: -25 bis +35°C</p> <p>Protection class: IP 44, housing: Galvanized zinc, seamlessly deep-drawn</p> <p>Coating: powder coated, white RAL 9016</p> <p>Diffuser: Polycarbonate opal; grid connection: 220 to 240 V, 50 / 60 Hz</p> <p>Light source: High power LED unit (18 W/1800Lm)</p> <p>Dimensions: 380 x 147 x 113 mm</p> <p>Wiring and electrical connection are to be provided by the customer.</p> <p><b>Total price:</b> .....: <b>EUR</b></p> <p>(Without refrigeration equipment, emergency equipment, interior fittings and installation)</p> <p><b>Installation</b> .....: <b>EUR</b></p>		





Belgien  
froid.viessmann.be

Dänemark  
koele.viessmann.dk

Deutschland  
kuehlen.viessmann.de

Estland  
kylm.viessmann.ee

Finnland  
kylma.viessmann.fi

Frankreich  
froid.viessmann.fr

Irland  
cooling.viessmann.co.uk

Lettland  
cooling.viessmann.com

Litauen  
saldymas.viessmann.lt

Niederlande  
koelen.viessmann.nl

Norwegen  
kjol.viessmann.no

Österreich  
kuehlen.viessmann.at

Polen  
chlodnicze.viessmann.pl

Russland  
holod.viessmann.ru

Schweden  
kyla.viessmann.se

Schweiz  
kuehlen.viessmann.ch

Spanien  
refrigeracion.viessmann.es

Vereinigtes Königreich  
cooling.viessmann.co.uk