

**TectoCell Compact 80 cold room**  
**TectoCell Compact 100 cold room and deep-freezing room**



## Contents

<b>1. Technical data</b>	3
1.1 Dimensions	3
1.2 Thermal insulation	3
<b>2. Properties and options</b>	3
<b>3. General information</b>	4
<b>4. Room surfaces</b>	4
<b>5. Hard polyurethane foam</b>	4
<b>6. Connections and joints of the room elements</b>	5
<b>7. Room installation</b>	6
<b>8. Floor elements</b>	7
8.1 Cold rooms with insulated floor elements	7
8.2 Seamless stainless steel floors	7
8.3 Stainless steel floor surface (with slip resistance classes)	7
8.4 T0 floor	8
8.5 Compact cold rooms without floor elements	8
<b>9. Cold room doors</b>	9
9.1 Description	9
9.2 Door positioning	9
9.3 Mounted outside in the door frame	9
9.4 Electrical wiring	9
9.5 Door dimensions	9
<b>10. Installation dimensions of the room door</b>	10
10.1 Door frame instead of a wall medial element	10
10.2 Dimensions pivot range room door panel	10
<b>11. Ceiling elements</b>	10
<b>12. Dimensions/lead time standard – in stock</b>	11
<b>13. Tender texts</b>	12
13.1 Features	12
13.2 Connecting the room elements	12
13.3 Room surfaces (except for floor interior top side)	12
13.4 Floor elements - floor top side	12
13.5 Rooms without floor elements	12
13.6 Cold room doors	12
13.7 Combination rooms	12
13.8 Delivery and installation	12
13.9 Shelf systems and refrigeration units, see cold portfolio	12
<b>14. Tender texts - Specifications</b>	13

## 1. Technical data

### 1.1 Dimensions

Room model	TectoCell Compact 80	TectoCell Compact 100
Wall thickness	80 mm	100 mm
External height with floor	2110 mm	2150 mm
	2410 mm	2450 mm
	2710 mm	2750 mm
External height without floor	2045 mm	2065 mm
	2345 mm	2365 mm
	2645 mm	2665 mm
Room sizes		
Width	1800 - 3600 mm	1800 - 3600 mm
Length	1200 - 12000 mm	1200 - 12000 mm

### 1.2 Thermal insulation

Wall thickness	80 mm	100 mm
Recommended temperature difference As per VDI 2055 ( $\Delta T$ in Kelvin)	38K	45K
Temperature range	+2° C to +60° C	-25°C to +60°C
U-value as per DIN EN 131651)	0.25 W/m <sup>2</sup> K	1) 0.20 W/m <sup>2</sup> K
Foam density	40 kg/m <sup>3</sup>	
Building material class	As per DIN EN 13501-1, classification as per F	
Insulation	Polyurethane - hard foam with cyclopentane	

## 2. Properties and options

- Quick and easy installation thanks to the tongue and groove system with self-centring eccentric cams
- Easy expansion and reassembly thanks to joints that require neither glue nor silicone
- Viessmann joint-free and continuously underlapped stainless steel floors
- Non-slip floor grouting
- Perfectly tailored system technology with optionally available refrigeration units and shelving systems
- High standard of packaging for protecting goods and transporting them safely
- Optionally without floor elements and with mounting frames for the room walls (plastic U-profile). The U-profile has sealing lips to seal down to the floor of the building
- Cold room with revolving door
- Optionally with interior lighting, thermometer and pressure compensation valve.

### 3. General Information

- Viessmann cold room elements are precisely and homogeneously manufactured with cyclopentane foamed polyurethane. They have low thermal conductivity values, high compressive strength and great stability.
- The element connection with a tongue and groove system and corrosion-protected eccentric cams enable fast assembly and disassembly.
- The elements of the room ceilings are not dimensioned for additional forces (snow load, rain water, wind pressure, etc.). During on-site installation, adequate reinforcement or static protection should be ensured before inspection, when a ceiling refrigeration unit is installed, or for other structures such as meat hangers, tubular tracks, etc.

### 4. Room surface

The room elements are available with the following facings:

**STO=**

Powder coating Viessmann standard white, similar to RAL 9016.

### 5. Hard polyurethane foam

Viessmann cold rooms are insulated effectively with cyclopentane foamed polyurethane and are tight thanks to the tongue and groove system. Cyclopentane enables precise foaming of the room elements and easy installation.

## 6. Connections and Joints of the Room Elements

The sandwich cold room panels (floors, walls, ceilings) are connected using a self-centring tongue and groove system. Eccentric cam locks with plastic housing and corrosion-resistant clamping hooks are foamed into the elements. The cam locks should be worked from the inside; the room does not need to be accessible from the outside during installation.

The wall panels are directly connected to the heat-insulated stainless steel cold room floor.

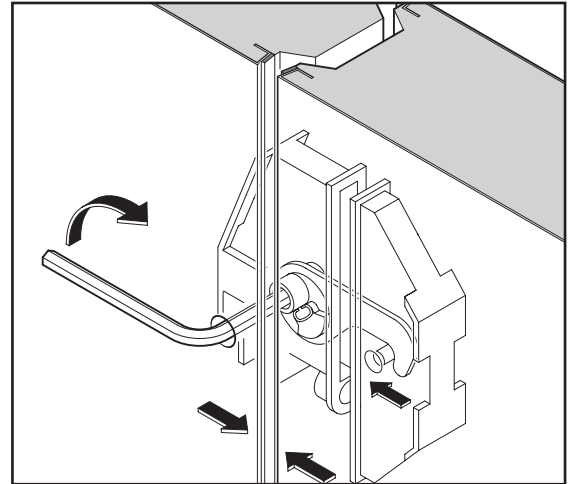

**TectoCell Compact walls with foamed-in cam lock connection**

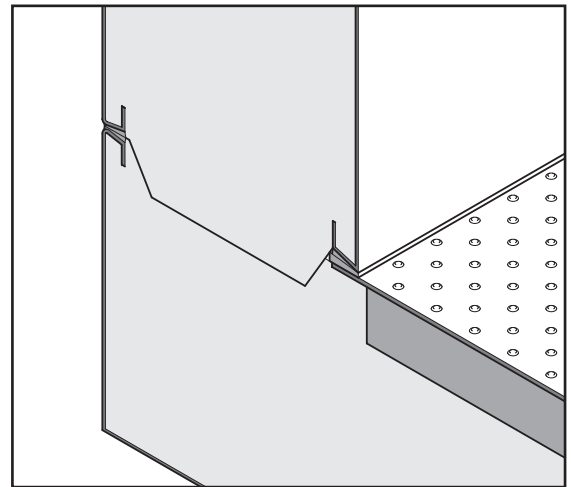

**Floor – wall connection**

## 7. Room installation

The room should be set up in a well aerated and ventilated space so that the heat generated by the refrigeration unit is safely discharged and a heating up of the installation area is avoided. The run time of the refrigeration unit is thereby reduced and with it the electricity costs, and the refrigeration unit is rested. The distance of the cold room from the building wall and the open space above the room must be at least 50 mm with a cold room temperature in the plus range and 100 mm with a cold room temperature in the minus range.

It must be ensured that the floor elements are laid only on a level and smooth floor (as per VOB specifications). For an uneven and non-level floor (e.g., concrete), the dimensional difference should be compensated by underlays.

Cold and deep-freeze rooms that are operated in the temperature range below  $-5^{\circ}\text{C}$  must be installed on base plates as protection against freezing underneath the room. Electric floor heating can also be used instead of the base plates.

### Outdoor installation

For outdoor installation, it should be ensured by local and on-site construction measures (self-supporting roofing and side walls) that the cold room is not exposed to weather impacts (snow load, rainwater, wind pressure, etc.). These precautions must be completed before installation.

When cold rooms are installed outdoors, discolouration of the paint may occur due to UV exposure.

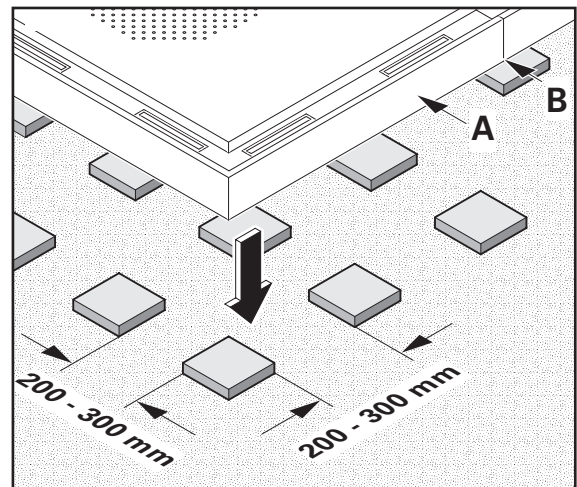

**TectoCell Compact 80 and 100 Cold Rooms and Deep-Freezing Units Room installation – Installation on floor plates**

## 8. Floor elements

T0 = standard floor  
Room without floor elements

### 8.1 Cold rooms with insulated floor elements

Floor structure:

- Austenitic stainless steel sheet, material no. 1.4301
- Pressure distribution plate
- PU hard foam with tongue and groove
- Bottom plate.

Features:

- Joints of the floor elements are seamless, underlapped continuously and interlocking and riveted during installation.
- Stainless steel surfaces have multi-directional non-slip properties (R11) due to a special Viessmann pressing process.
- Permissible loads of the room floors:

Wheel load in N > 1 cm <sup>2</sup> , hard bakery wheel	Wheel load in N > 4 cm <sup>2</sup> rubber wheel	Surface load in N/m <sup>2</sup>
250	1000	30,000

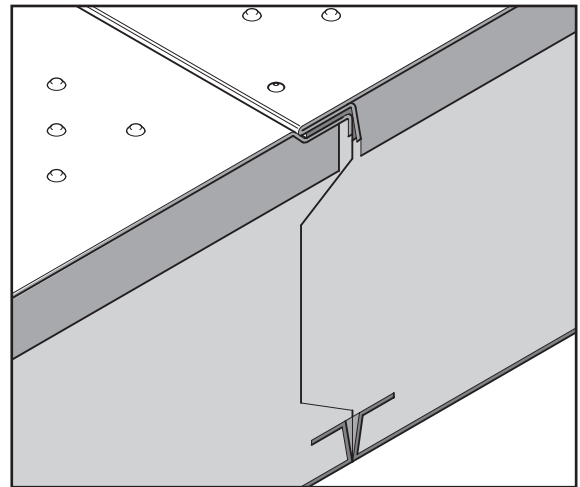

**Underlapping of the stainless steel floors**

### 8.2 Seamless stainless steel floors

For the **stainless steel floors**, the joint between the floor elements is seamless, and continuously underlapped, with a glued-on, high-quality sealant.

The underlapping is riveted during installation, to keep moisture from penetrating into the room floor and thus prevent germ formation.

### 8.3 Stainless steel floor surface (with slip resistance class)

**Greater safety thanks to slip-resistant stainless steel floor surface.**

Our stainless steel room floors have multi-directional non-slip properties (R11) thanks to a special Viessmann pressing process.

## 8. Floor elements

### 8.4 T0 floor

Stainless steel floor for TectoCell Compact 80 and 100 cold rooms and deep-freezing units. Drivable up to 1000 N per rubber wheel.

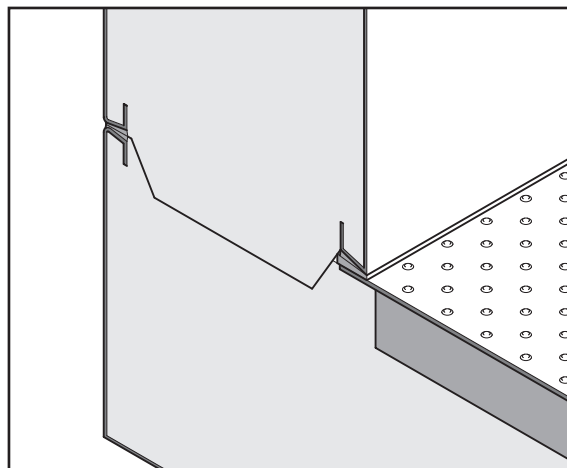

Connection T0 stainless steel floor - room wall without radius

### 8.5 Compact cold rooms without floor elements

The cold room can be installed without floor elements in rooms at positive temperatures. The wall elements are attached using plastic U-profiles, which are screwed onto the support frame floor at 600 mm intervals. They are designed to form a seal with the floor of the building. During installation, the wall elements are internally and externally riveted or screwed to the U-profiles every 300 mm.

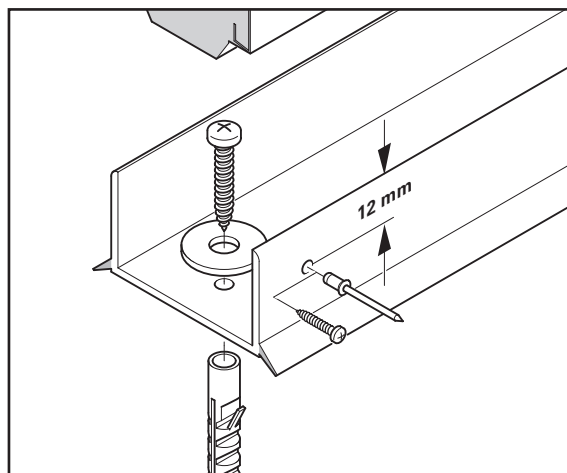

Attaching the mounting frame

## 9. Cold room doors

### 9.1 Description:

- An outward opening single leaf hinge door with magnetic seal, as well as removable, upward, and three-dimensionally adjustable door hinges.
- Rotary lever lock with spring-loaded latch and cylinder lock, as well as emergency-opening device for opening the locked door from the inside.
- Door hinged on right or left.
- Door leaf foamed with polyurethane hard foam with cyclopentane.
- Threshold cover plate made of stainless steel for room with thermally insulated floor elements.

### 9.2 Door positioning:

with TectoCell Compact 80 and 100 cold rooms

- The door can be positioned on the door side within the grid
- The minimum distance of the door opening to the room corner is at least 450 mm.

### 9.3 Installed outside in the door frame:

- Door frame heating (see table)
- The following can be optionally ordered: Thermometer, light switch and pressure compensation valve with or without heating. These items are delivered as loose items and must be installed on site.
- The pressure compensation valve is designed for a refrigerating capacity of the refrigerating unit up to a maximum of 5 kW. In the case of a higher refrigerating capacity, a larger pressure compensation valve or several of them must be installed.

### 9.4 Electrical wiring

All cables must be integrated and wired during the installation process.

### 9.5 Door - dimensions<sup>1)</sup>

Wall thickness	80	100
External height with floor (mm)	2110	2150
	2410	2450
	2710	2750
External height without floor (mm)	2045	2065
	2345	2365
	2645	2665
LW x LH <sup>2)</sup>	900 x 1800	900 x 1800
	900 x 2000	900 x 2000
	900 x 2200	900 x 2200
Door frame heating	without	without/with

1) Workplace regulations in their currently valid version must be taken into consideration

2) For cold rooms without a floor, the clearance height is increased by 15 mm.

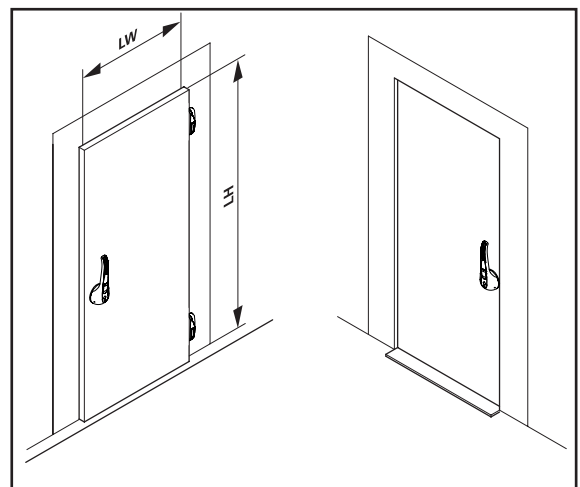

## 10. Installation dimensions of the room door

### 10.1 Door frame instead of a wall medial element

The door frame can be positioned 300 mm on any location of the room walls in the grid. A distance from the room corner of at least 300 mm to the left or right is required (see drawing, dimension B and C). D and E = minimum distance of 450 mm.

Inside width Door clear width (mm)	Distance A (mm)	Width Door frame F (mm)
900	150	1200

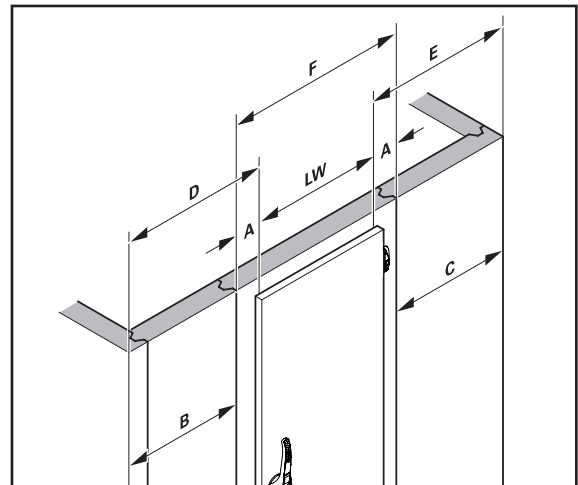

Middle door frame element

### 10.2 Dimensions of pivot range of room door leaf

See figure at right

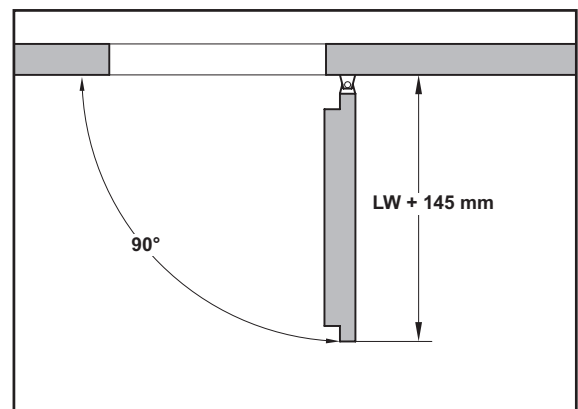

## 11. Ceiling elements

The elements of the room ceilings are not dimensioned for additional forces (snow load, rain water, wind pressure, etc.).

During on-site installation, adequate reinforcement or static protection should be ensured before inspection, when a ceiling refrigeration unit is installed, or for other structures such as meat hangers, tubular tracks, etc.

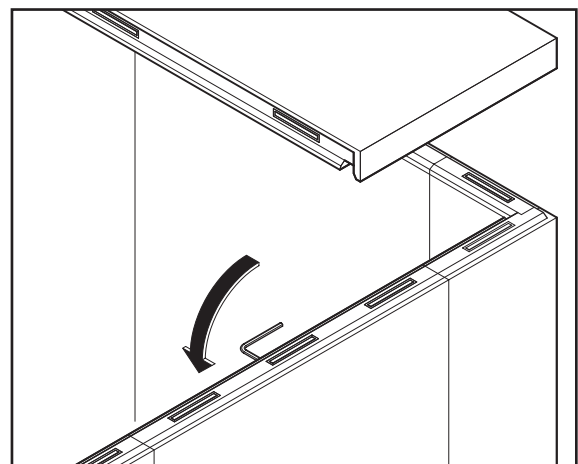

Ceiling installation

## 12. Dimensions/lead time standard – in stock

In-stock cold rooms and deep-freezing rooms:

Room model	TectoCell Compact 80	TectoCell Compact 100
Exterior height with standard floor T0	2110 mm 2410 mm 2710 mm	2150 mm 2450 mm 2750 mm
External height without floor	2045 mm 2345 mm 2645 mm	2065 mm 2365 mm 2665 mm
Width	1800 - 3600 mm	1800 - 3600 mm
Length	From 1200 mm in grid of 100 mm to 12000 mm	
Lead time	ex-warehouse	

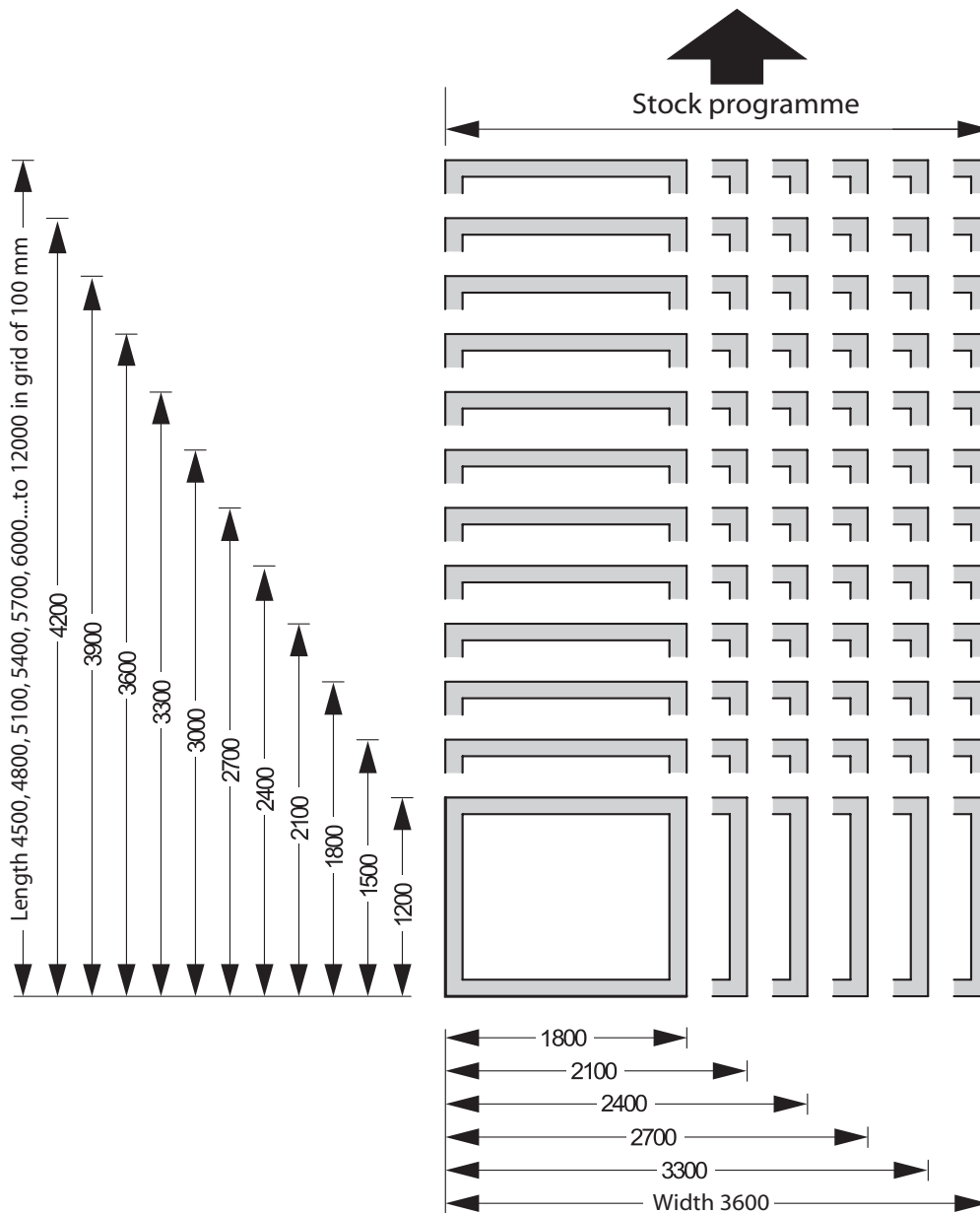

## 13. Tender text

### 13.1 Features:

Thermal insulation foamed with polyurethane hard foam with cyclopentane (closed cell).

- Foam density of 40 kg/m<sup>3</sup>.
- Heat conductivity group 025 as per DIN 4108.
- Building material class as per DIN 4102, classification as per B3.

Wall thickness (mm)	80	100
Recommended temperature difference As per VDI 2055 $\Delta T =$ (Kelvin)	38K	45K
U-value in accordance with DIN EN 131651 (W/m <sup>2</sup> *K) <sup>1)</sup>	0.25	0.20

- Thermal bridge-free room elements in sandwich design, sturdy, self-supporting and accurately dimensioned.
- Maximum self-supporting span width of ceiling elements: 3600 mm
- TectoCell Compact - T0 floor
- Wall and ceiling elements, as well as doors are wood-free.

### 13.2 Connecting the room elements

The room elements (floors, walls, ceilings) are connected using a self-centring tongue and groove system. Eccentric cam locks are foamed with plastic housing and corrosion-resistant clamping hooks.

### 13.3 Room surfaces (except for floor interior top side)

STO: Powder coating Viessmann standard white, similar to RAL 9016.

- The joints of the wall elements are executed with a tongue and groove system and an interstitial PE sealant.

### 13.4 Floor elements - floor top side

**Stainless steel floor**  
(Material no. 1.4301 - austenitic stainless steel).

- Joints of the floor elements are seamless, underlapped continuously and interlocking and riveted during installation.
- Stainless steel surfaces have multi-directional non-slip properties (R11) due to a special pressing process.
- Permissible loads of the room floors:

Wheel load in N > 1 cm <sup>2</sup> , hard bakery wheel	Wheel load in N > 4 cm <sup>2</sup> rubber wheel	Surface load in N/m <sup>2</sup>
250	1000	30,000

- **Standard floor:** Stainless steel floor for TectoCell Compact 80 and 100 cold rooms and deep-freezing units (without radius to room wall).

### 13.5 Rooms without floor elements

Support frame (plastic U-profile) for the Support for wall elements (only usable in positive temperature ranges).

### 13.6 Cold room doors

An outward opening single leaf hinge door with magnetic seal, as well as removable, upward, and three-dimensionally adjustable door hinges.

Rotary lever door lock with spring-loaded latch and cylinder lock, as well as emergency-opening device for opening the locked door from the inside.

Door hinges optionally DIN right  or left .

Door panel with cyclopentane foamed polyurethane hard foam.

Threshold cover plate made of stainless steel for rooms with thermally insulated floor elements.

Adequate lighting as per workplace regulations must be provided on-site as required.

### 13.7 Combination rooms

With TectoCell combination rooms, one or more partition walls are built in. The floors, walls and ceilings are supplied with a tongue and groove connection.

### 13.8 Confinement columns (Optional)

For columns 300 x 300 mm or 600 x 600 mm. Consisting of elements of 100 mm wall thickness and attachment material for on-site processing and assembly.

### 13.9 Delivery and installation

Delivery and installation are made as per our "Special Conditions for delivery and installation of cold rooms."

### 13.10 Shelf systems and refrigeration units, see cold portfolio

<sup>1)</sup> does not apply to floor elements

## 14. Tender text - Specifications

Serial no.	Number	Item	Unit price	Total price
		<p><b>Viessmann TectoCell Compact cold room and deep-freezing room</b></p> <p><b>Overall external dimensions</b>  Width: _____ mm  Length: _____ mm  Height: _____ mm</p> <p><b>Room model:</b>  <input type="checkbox"/> <b>TectoCell Compact 80</b>  Wall thickness 80 mm (U-value = 0.25 W/m<sup>2</sup>K as per DIN EN 13165)  for temperature differences up to ΔT = 38 K as per DIN 2055  Temperature range -20°C to +60°C</p> <input type="checkbox"/> <b>TectoCell Compact 100</b> Wall thickness 100 mm (U-value = 0.20 W/m <sup>2</sup> K as per DIN EN 13165) for temperature differences up to ΔT = 45 K as per DIN 2055 Temperature range -25°C to +60°C <p><b>Wall structure</b>  Elements are connected by a self-centring tongue and groove seal system. Foamed, corrosion-protected cam locks for a friction-locked connection of the elements with each other. The eccentric cam locks are firmly foamed in cold bridge-free housings.</p> <p>Surfaces of the wall, ceiling, and door elements are galvanized sheet steel inside and out, powder-coated, white similar to RAL 9016</p> <p><b>Floor:</b>  <input type="checkbox"/> <b>T0 Standard floor</b>  Floor element interior side stainless steel (1.4301), pressed slip-resistant, glued to waterproof glued chipboard/multiplex board, overlapping at the joint of the floor elements  Permissible load/wheel: 1000 N/wheel  Load area: 4 cm<sup>2</sup>  Permissible surface load: 30,000 N/m<sup>2</sup></p> <p><b>Floor elements - stainless steel surface</b>  Wheel &lt; 1cm<sup>2</sup>    Wheel &lt; 4cm<sup>2</sup>    Surface 1m<sup>2</sup>  250N                    1000N                    30.000N</p> <p><b>Doors:</b>  An outward-opening single leaf hinge door, overlying, with magnetic frame seal profile and upward-facing, adjustable hinges, compression lever with spring-loaded latch, lockable, inside with emergency opening device, door hinges optionally DIN left or right.</p> <p>1. Single-leaf hinge door  a) Middle door element  Clear width _____ x _____ mm  Door stop _____    DIN left <input type="checkbox"/>                    DIN right <input type="checkbox"/></p>		

## 14. Tender text - Specifications

Serial no.	Number	Item	Unit price	Total price
		<p><b>Accessories</b></p> <p><b>White light switch, surface-mounted without cable</b>    <b>Additional cost:</b></p> <p><b>Thermometer</b>    <b>Additional cost:</b></p> <p><b>Pressure equalisation valve</b>    <b>Additional cost:</b>  <input type="checkbox"/> with heater    <input type="checkbox"/> without heater            Up to 5 kW refrigeration capacity</p> <p><b>Strip curtain</b>            For wall installation, clear width _____ x _____ mm    <b>Additional cost:</b>  <b>Additional cost:</b>            For ceiling installation _____ x _____ mm    <b>Additional cost:</b></p> <p><b>Underneath ventilation</b>    <b>Order</b>  <b>No. 00060001</b>            30 mm thick tiles for underneath ventilation of the room</p> <p><b>Floor cover</b>    <b>Order No. 7021 144</b>            For covering rooms with underlying base plates</p> <p><b>Access ramp</b>    <b>Order no.</b>            _____            Material: Stainless steel sheet            Height _____ mm, length _____ mm, width _____ mm            For door with clear width of _____ mm.</p> <p><b>Meat and sausage hanging rails</b>    <b>Additional cost:</b></p> <p><b>LED refrigerator and freezer compartment light (door frame)</b>  <b>Additional cost:</b>            Ambient temperature: min. -30 ° C to max. +45 ° C            Protection class: IP44, housing: Galvanized steel            Coating: White powder-coated RAL 9016            Diffuser: Polycarbonate, electrical equipment: Flexible wiring            Light sources: High-power LEDs (10W), luminous flux: 1213 lm            Wiring and electrical connection are to be provided by the customer.</p> <p><b>LED refrigerator and freezer compartment light (ceiling)</b>  <b>Additional cost:</b>            -25 to +35°C            Protection class: IP 44, housing: Galvanized zinc, seamlessly deep-drawn            Coating: Powder-coated, white RAL 9016            Diffuser: Polycarbonate opal; grid connection: 220 to 240 V, 50 / 60 Hz            Light source: High power LED unit (18 W/1800Lm)            Dimensions: 380 x 147 x 113 mm            Wiring and electrical connection are to be provided by the customer.</p> <p><b>Total price: .....: EUR</b>            (Without refrigeration equipment, emergency equipment, interior fittings and installation)</p> <p><b>Installation .....: EUR</b></p>		



Austria  
Viessmann K hlsysteme Austria GmbH  
Telephone +43 72 35 66367-0  
office\_vk\_at@viessmann.com  
**kuehlen.viessmann.at**

Belgium  
Viessmann Nederland B.V.  
Telephone +31 85 018 7460  
info-ref-be@viessmann.com  
**cooling.viessmann.com**

Czech Republic  
Viessmann, spol. s r.o.  
Telephone + 420 257 090 900  
viessmann@viessmann.cz  
**cooling.viessmann.com**

Denmark  
Viessmann Refrigeration Systems ApS  
Telephone +45 4120 5420  
info.dk@viessmann.com  
**koele.viessmann.dk**

Estonia  
Viessmann K lmas steemid O   
Telephone +372 675 5150  
info.ee@viessmann.com  
**kylm.viessmann.ee**

Finland  
Viessmann Refrigeration Systems Oy  
Telephone +358 19 537 8000  
info.fi@viessmann.com  
**cooling.viessmann.com**  
Viessmann Kylm j rjestelm t Oy  
Telephone +358 19 537 8000  
info.fi@viessmann.com  
**kylma.viessmann.fi**

France  
Viessmann Technique du Froid S. .r.l.  
Telephone +33 3 87 13 08 13  
france@viessmann-refrigeration.com  
**froid.viessmann.fr**

Germany  
Viessmann K hlsysteme GmbH, Hof  
Telephone +49 9281 814-0  
Viessmann K hlsysteme GmbH, Mainz  
Telephone +49 61315 7046-17  
kuehlsysteme@viessmann.de  
**cooling.viessmann.co.uk**

Ireland  
Viessmann Refrigeration Systems Limited  
Telephone +353 1 617 7930  
sales@viessmann-coldtech.ie  
**cooling.viessmann.co.uk**

Latvia  
Viessmann Refrigeration Systems Latvia fili le  
Telephone +371 6782 8449  
info.lv@viessmann.com  
**cooling.viessmann.com**

Netherlands  
Viessmann Nederland B.V.  
Telephone +31 85 018 7460  
info-ref-nl@viessmann.com  
**koelen.viessmann.nl**

Norway  
Viessmann Refrigeration Systems AS  
Telephone +47 3336 3500  
post@viessmann.no  
**kjol.viessmann.no**

Poland  
Viessmann Systemy Chlodnicze Sp. z o.o.  
Telephone +48 22 882 0020  
info.pl@viessmann.com  
**chlodnicze.viessmann.pl**

Russia  
Viessmann Group – Refrigeration Systems  
Moscow, St. Petersburg  
Telephone +7 499 277 1260  
**holod.viessmann.ru**

Slovakia  
Viessmann, s.r.o.  
Telephone +421 32 23 01 00  
viessmann@viessmann.sk  
**cooling.viessmann.com**

Sweden  
Viessmann Refrigeration Systems AB  
Telephone +46 8 5941 1200  
info.refrigeration@viessmann.se  
**kyla.viessmann.se**

Switzerland  
Viessmann (Schweiz) AG  
Telephone +41 56 418 67 11  
info@viessmann.ch  
**kuehlen.viessmann.ch**

United Arabian Emirates  
Viessmann Middle East FZE  
Telephone +971 43724247  
refrigeration@viessmann.ae  
**cooling.viessmann.com**

United Kingdom  
Viessmann Refrigeration Systems Limited  
Telephone +44 1952 457157  
sales@viessmann-coldtech.co.uk  
**cooling.viessmann.co.uk**