









NATURAL
REFRIGERANT
R290

Key Features

The IM-45NE-HC and IM-45CNE-HC are compact sized cube ice makers, which utilises Natural Refrigerant R290.

-  Energy efficient, with savings of 20% compared to HFC equivalent model.*
-  Smallest member of the Emerald Class, Hoshizaki's new range of climate friendly ice makers.
-  Can produce up to 46kg of cube ice per 24 hours (AT.10°C.WT.10°C).
-  Unique ice making system that has an automatic rinse cycle. After every new batch of ice, the water reservoir drains and refills with fresh water. System comes with a magnetic water pump that has no direct coupling, which prevents any leakage.
-  Closed water circuit offers the ultimate contamination protection, by reducing the number of points at which impurities can enter the ice making process.
-  Electronically controlled to ensure an optimised ice making process under varying circumstances without the need for physical adjustments. Quality of ice is always consistent.
-  Easily cleanable air filter allows end-users to carry out routine cleaning schedules. Extends product life expectancy and reduces the frequency and costs of maintenance call-outs.
-  Stainless steel exterior with integrated Bin door handles provides a hygienic and high quality finish.

* Based on Internal comparative study. Please contact your local sales branch to find out more.

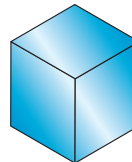

Ice: Standard Cube (L)
Size: Approx. 28 x 28 x 32mm



Available Models

Model	Air Cooled	Water Cooled
IM-45NE-HC	✓	
IM-45CNE-HC	✓	

Bins

Model	Type of Bin	Max. Bin Capacity approx.
IM-45NE-HC	Self-contained	18kg
IM-45CNE-HC	Self-contained	15kg

Production

Model	Ice Production per 24h approx.	Temperature	Water Consumption per 24h approx.
IM-45NE-HC	Approx. 40kg (5mm) / 46kg (15mm)	AT.10°C, WT.10°C	0,18m ³
	Approx. 36kg (5mm) / 42kg (15mm)	AT.21°C, WT.15°C	0,11m ³
	Approx. 30kg (5mm) / 34kg (15mm)	AT.32°C, WT.21°C	0,10m ³
IM-45CNE-HC	Approx. 40kg (5mm) / 46kg (15mm)	AT.10°C, WT.10°C	0,18m ³
	Approx. 36kg (5mm) / 42kg (15mm)	AT.21°C, WT.15°C	0,11m ³
	Approx. 30kg (5mm) / 34kg (15mm)	AT.32°C, WT.21°C	0,10m ³

For more information visit our website at www.hoshizaki-europe.com

Hoshizaki Europe B.V. retains the right to change products and their specifications without prior notice.



IM-45NE-HC

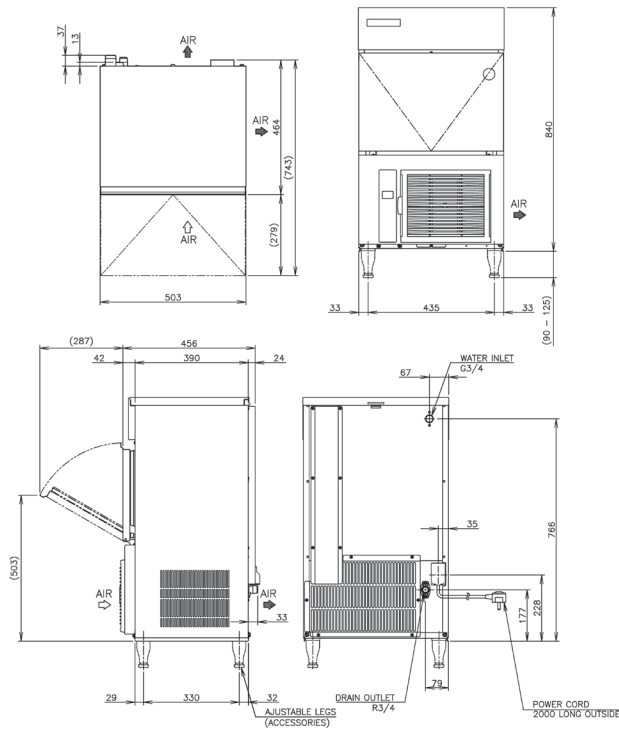

D15998 / 2015.04.24

IM-45CNE-HC

➔ CAD drawings available on our website

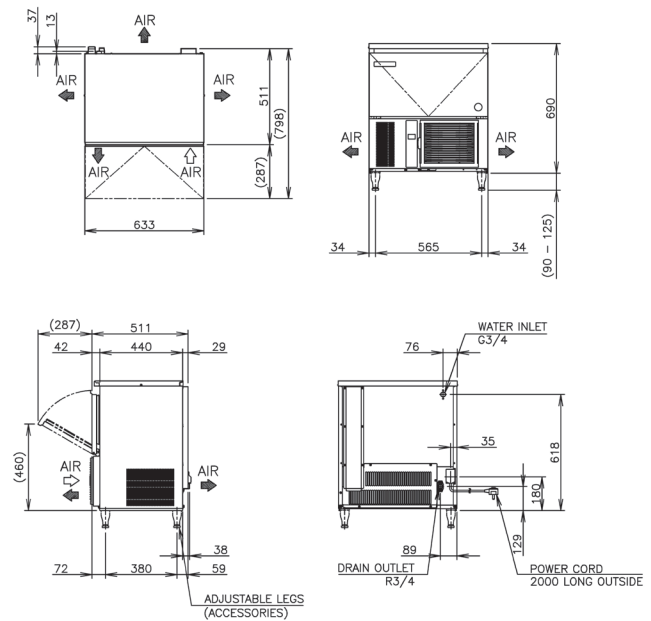

D15997 / 2015.04.24

Specifications

	IM-45NE-HC	IM-45CNE-HC
Dimensions W x D x H (mm)	503mm x 456mm x 840mm	633mm x 511mm x 690mm
AC Supply Voltage	1/220-240V 50Hz	1/220-240V 50Hz
Electric Consumption (AT.32°C, WT.21°C)	275W	275W
Heat Rejection (AT.32°C, WT.21°C)	665W	665W
Refrigerant Charge	R290 / 70g	R290 / 70g
Isolation	Polyurethane	Polyurethane
Weight Gross / Net	50kg / 44kg	55kg / 45kg

Operation Requirements

Ambient Temperature	1 - 40°C
Water Supply Temperature	5 - 35°C
Water Supply Pressure	0,7-8bar (0,07-0,8MPa)
Voltage Range	Rated Voltage ± 6%

Accessories

Scoop
Leg
Installation Kit