

IncuSafe

CO₂ Incubators

165 L



MCO-171AICD / MCO-171AICUVD



*Standard for Model MCO-171AICUVD

Easy-to-Use 11 hours 180°C Dry Heat Sterilization Model

PHCbi's Dry Heat Sterilization CO₂ incubator with inCu-saFe germicidal interior. The heat dissipation and maximum current lowering functions allow two units to be stacked on top of each other with one delivering dry heat sterilization while the other is used for culture purposes.

UV-LED lamp delivers long-lasting performance

An UV-LED germicidal lamp is positioned in the rear duct and switches on to sterilise the water used in the humidifying pan. The lamp does not use harmful mercury and delivers better sterilization compared to conventional UV lamps. *

(Based on internal test results)

Saves replacing germicidal lamp time and reduces running costs

The use of a long-lasting LED lamp eliminates regular replacement of germicidal lamps even with 30 door openings per day.

Integrated Shelf Supports improve cleaning and increases culture capacity

Cleaning the chamber is easier and more efficient as the shelf support section minimises the interior items used. It is now possible to place 20 100ø mm Petri dishes on each tray.



Stacking for work efficiency

Fiberglass insulation minimises heat dissipation from the incubator. This allows one unit to be used for dry-heat sterilization while the other continues normal incubation when two incubators are stacked.



180°C Dry Heat Sterilization

The new structural design enabling quick in-chamber temperature rising and reducing temperature distribution variations provides dry heat sterilization lasting approximately 11 hours.



Improved Usability

The full-colour LCD touch panel allows efficient management of the functions. The USB port next to the panel enables transferring logged data to memory devices. The new designed incubator has an improved easy-to-grasp handle.

Dry Heat sterilizing CO₂ Incubators



Advanced product design

The UV-lamp is installed in the rear duct for only irradiating the water in the humidifying tray. The tray cover and rear duct prevent UV light from leaking into the culturing areas, ensuring that it does not affect any samples.

Reduced running cost

A single heater with excellent heat resistance ensures efficient power usage during incubation and dry heat sterilization, helping to reduce maximum current draw.

Increased work efficiency

Recalibration of temperature and CO₂ concentration are not needed after sterilization, culturing can be restarted immediately after a sterilization cycle has been conducted.

Model Number	MCO-171AICD-PE / MCO-171AICUVD-PE	
Dimensions		
External dimensions (WxDxH) ¹⁾	mm	620 x 755 x 905
Internal dimensions (WxDxH)	mm	490 x 523 x 665
Volume	litres	165
Net weight (approx)	kg	80
Performance		
Temperature control range & fluctuation	°C	AT +5 to +50, ±0.1 (AT: 5°C to 35°C)
Temperature uniformity ²⁾	°C	±0.25
CO ₂ control range & fluctuation ²⁾	%	0 to 20, ±0.15
Humidity level & fluctuation	%RH	95, ±5
Control		
Temperature sensor		Thermistor
CO ₂ sensor		Dual IR
Display		Colour LCD touchscreen
Construction		
Exterior material		Painted steel (Bottom and rear cover have no paint.)
Interior material		Stainless steel copper-enriched alloy
Insulation material		Glass-wool insulation
Heating method		Heater jacket system
Sterilisation method ³⁾		Dry heat sterilisation, 180°C, 11 hours
Outer door	qty	1, Field-reversible
Electric door lock with password		Standard
Inner door	qty	1
Shelves		4 x Stainless steel copper-enriched alloy
Shelf dimensions (W x D x H)	mm	470 x 450 x 12
Max. load per shelf	kg	7
Access port	qty	1
Access port position		On the back side
Access port diameter	∅ mm	30
Alarms (R = Remote Alarm, V = Visual Alarm, B = Buzzer Alarm)		
Power failure		R
Temperature deviation		V-B-R
High temperature		V-B-R
CO ₂ deviation		V-B-R
Door open		V-B
Electrical and noise level		
Power supply	V	220 - 240
Frequency	Hz	50/60
Noise level ⁴⁾	dB	25
Options		
UV System Set		MCO-LUVSD-PW (Standard in MCO-171AICUVD)
Gas Regulator		MCO-010R-PW
Gas Auto Changer		MCO-21GCP-PW
Tray (same as standard accessory)		MCO-170ST-PW
Half Tray		MCO-25ST-PW
Reinforced Tray (InCu-saFe®)		MCO-170RT-PW
Double-stacking Bracket ⁵⁾		MCO-170PS-PW
Stacking Plate ⁵⁾		MCO-170SB-PW, MCO-230SB-PW
Roller Base		MCO-170RB-PW
Optional communication systems		
Interface Board ⁶⁾ ; for LAN		MTR-L03-PW
Interface Board ⁶⁾ ; for RS-232C/RS-485		MTR-480-PW
Interface Board (4-20mA)		MCO-420MA-PW
Quality Management System ⁷⁾		
Certification		ISO9001
Mod-bus interface board		MTR-MODB1-PW

Dimensions unit: mm

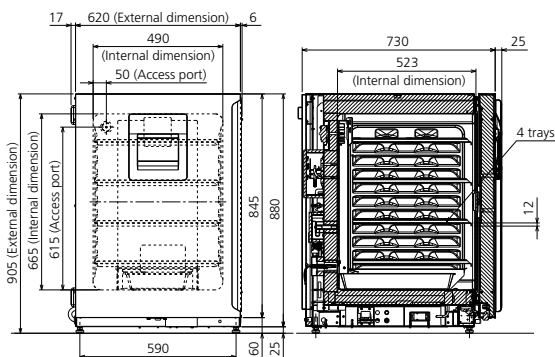

Notes:

1) Exterior dimensions of main cabinet only, excluding handle and other external projections.

2) Ambient temperature 23°C, setting 37°C, CO₂ 5%, no load.

3) Dry heat sterilisation can be performed only for the chamber and inner attachments with standard specifications, not for any other objects.

4) Nominal value.

5) If stacking two incubators, make sure the double-stacking dedicated securing hardware and spacer are used.

6) Only for the Data acquisition system MTR-5000 user. MCO-171AICD series can only be fitted with one communications interface.

7) MCO-171AICD and MCO-171AICUVD are for laboratory use.

Caution: PHC Corporation guarantees this product under certain warranty conditions. However, please note that PHC Corporation shall not be responsible for any loss or damage to the contents of the product.

PHCbi

PHC Europe B.V.
Eikdonk 1 | 4825 AZ Breda | Netherlands
T: +31 (0) 76 543 3833

www.phchd.com/eu/biomedical