

Instructions for use - ExGuard

Model: 600W



Original Instructions for use

Item nr. 765042431
Revision nr. 20201112
English

Quick Guide - ExGuard

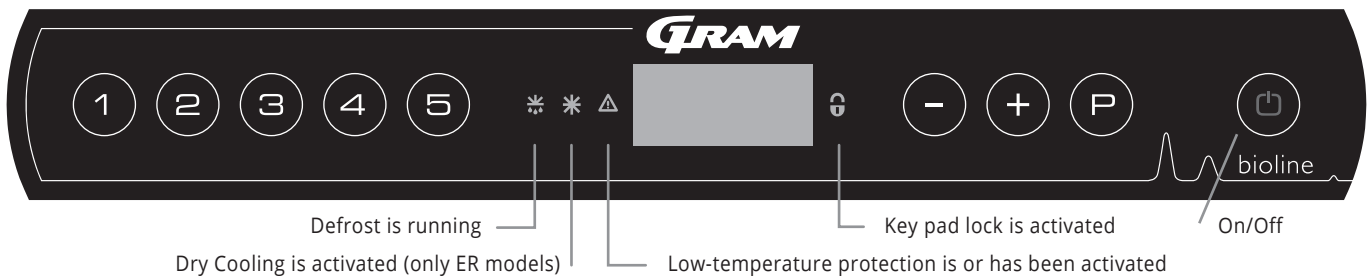

On/Off

Press the button to turn the cabinet on. Press the button for 6 seconds to turn the cabinet Off. The software version of the cabinet will be shown when turning the cabinet on, followed by the variant and a display test. The cabinet is ready when the temperature is displayed. The cabinet will automatically start a defrost-cycle when turned on, and terminate it again after a system check.



ATTENTION: Please note, turning Off the cabinet will result in the extraction system also powering down. Ultimately resulting in a rise in temperature inside the storage chamber

Setting the temperature

Temperature adjustments are done by holding the button and pressing either or . Confirm the settings by letting go of the buttons.

User menu and alarm settings

Menu Access + →	↓	→		
	dC*			
Local alarm settings	LAL	LHL	[° C]	Upper alarm limit. Code for activated alarm [A2]
		LLL	[° C]	Lower alarm limit. Code for activated alarm [A3]
		LHd	[Min.]	Delay of upper alarm limit
		LLd	[Min.]	Delay of lower alarm limit
		dA	On/Off	Door alarm. Code for activated alarm [A1]. [1=On / 0=Off]
		dAd	[Min.]	Delay of door alarm
		bU	On/Off	Acoustic signal for alarm codes [A1], [A2] and [A3]. [1=On / 0=Off]
External alarm settings	EAL	EHL	[° C]	Upper alarm limit. Code for activated alarm [A4]
		ELL	[° C]	Lower alarm limit. Code for activated alarm [A5]
		EHd	[Min.]	Delay of upper alarm limit
		ELd	[Min.]	Delay of lower alarm limit
		dA	On/Off	Door alarm. Code for activated alarm [A1]. [1=On / 0=Off]
		dAd	[Min.]	Delay of external door alarm
		bU	On/Off	Acoustic signal for external alarm codes [A1], [A4], [A5]. [1=On / 0=Off]
Offset of sensors	CAL	CA	[° K]	Calibration of A-sensor. Reference sensor for the refrigeration system
		CE	[° K]	Calibration of E-sensor. Reference sensor for the display and alarms
	ALL			Activation of escorted alarm limits. [FAS]= locked limits / [ESC] = follows setpoint
	dEF			Number of defrosts per 24 hours (4 is factory setting)
	dPS			Reference sensor for the display (A, E or F) (E is factory setting)

* Only ER-models: Dry cooling - dC - [HO=Off/H1= On]. Press and hold + , press to proceed to "LAL"

Example: Setting the upper limits for the alarms; LHL

- ↳ Press and hold + until the display shows LAL
- ↳ Press to select LAL, LHL is now shown in the display
- ↳ Press to select LHL, 25 is shown in the display
- ↳ Press or to set the desired value for the upper temperature limit
- ↳ Press to confirm the set value
- ↳ Press to return to LAL
- ↳ Press to reach the next level, LLL
- ↳ LHd, LLd, dA, dAd and bU are located on the same level
- ↳ Press three times to leave the user menu

Quick Guide - ExGuard

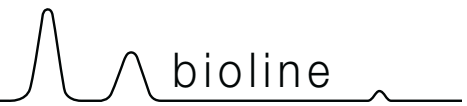

Alarms

Alarm codes	A1	Door alarm
	A2	The upper alarm limits, (LHL) is or has been activated
	A3	The lower alarm limits, (LLL) alarm is or has been activated
	A4	External high alarm EHL is or has been activated (see page 24)
	A5	External low alarm ELL is or has been activated (see page 24)

Canceling an acoustic alarm

Canceling a door alarm: [A1] flashes in the display. Press P to cancel.

Canceling a temperature alarm: [A2, A3] Flashes in the display. Press P to cancel.

The display will continue to flash if the temperature is outside the alarm limits, and will continue until the temperature has recovered.

Reading Max/Min temperature

Read the highest recorded temperature inside the cabinet by holding down + . Read the lowest recorded temperature inside the cabinet by holding down - .

Reading the alarm history - Example [A2]

[A2] flashes in the display - This means that the temperature has exceeded the set value for the upper temperature limit, LHL. Press P to cancel the [A2]. The display continues to flash, indicating that there is information in the alarm history. Press + , Htt (High temperature time) is shown, press P to see for how long the temperature was above the set alarm limit. Press + to return to Htt. Press + to reach Ht (Highest temperature). Press P to read the highest recorded temperature during Htt.

Press + to return to Ht and press + again to leave the alarm history function.

The procedure for reading an [A3] alarm is identical, apart from entering the alarm history with the - button.

When reading out temperatures below set limits, the parameters are Ltt and Lt.

A flashing display with no alarm codes indicates that the alarm codes have been canceled, but the alarm system contains information.

Resetting Max/Min and alarm history

Resetting of the Max/Min and alarm history is done by holding - and + for more than 3 seconds, an acoustic signal will be given when reset is complete.

Sensor read-out and error codes

Menu Access $\text{P} + \text{S} \rightarrow$	\downarrow	$\text{P} \rightarrow [^{\circ}\text{C}]$	Display code and its message	
Sensor for refrigeration system	P-A	Value on sensor for refrigeration system	F1	Error on sensor for refrigeration system
Sensor for evaporator	P-b	Value for evaporator sensor	F2	Error on evaporator sensor
Sensor for condensor	P-C	Value for condensor sensor	F3	Error on condensor sensor
Sensor 2 for condensor	P-d	Value for condensor sensor 2	F4	Error on condensor sensor 2
Sensor for display and alarms	P-E	Value for display and alarm sensor	F5	Error on sensor for display and alarm
An overheated condensor can be caused by a clogged condensor - clean the condensor			F7	Overheated condensor
Open door indicator. Alarm [A1] will activate if the door is open longer than alarm limits.			-0-	Door open

Table of Content

Table of Content	4	Escorted / set alarm limits.....	30
Safety	5	Defrosts / 24 hours	30
Before you proceed	5	Display sensor.....	31
Cabinet components	6	Start-up ExGuard	32
Installation	8	The digital display (7 keys)	32
Setting up.....	8	Walkthrough of menu.....	33
Anti tilt bracket	9	Error codes - ExGuard	34
Setting up.....	10	ExGuard - Opening and closing door ...	35
Connection to ventilation system	11	Parameter settings	36
Voltage-free contact.....	12	Damper Open time.....	36
Connection to electricity	13	Feedback sensor	37
Frame earthing.....	14	Feedback sensor activation	37
ExGuard control panels	15	Door Lock open time	38
Control panels.....	15	Door alarm activation.....	38
Start-up - conventional operation	16	Door alarm delay.....	39
The digital display (9 keys)	16	Extraction alarm.....	40
Walkthrough of menu.....	17	Extraction extra.....	41
Error codes	18	Periodic extraction frequency	41
Dry cool	19	Buzzer	42
Local alarm settings	20	Ordinary use	43
Local high alarm.....	20	Regular maintenance	44
Local low alarm	20	Cleaning	44
Local high alarm delay	21	Door gasket.....	44
Local low alarm delay.....	21	General info	45
On / Off local door alarm	22	Responsibility.....	45
Delay for local door alarm.....	22	Service	45
Local acoustic settings	23	Defrost water	46
External alarm settings	24	Door closing mechanism	46
External high alarm	24	Access port.....	47
External low alarm	24	Important	48
External high alarm delay.....	25	Disposal	49
External low alarm delay	25	Datasheet	50
On/Off external door alarm.....	26	Declaration of conformity	51
External door alarm delay.....	26	Declaration of conformity	51
External acoustic settings.....	27	General info	52
Parameter settings	28	Piping diagram	52
Sensor offset.....	28	Wiring diagram.....	53

Copyright © 2006-2020 Gram BioLine, a division of Gram Commercial, Denmark. All rights reserved.

The content of this publication is owned by Gram BioLine, unless otherwise noted, and is protected by Danish and international copyright laws and provisions. Information and images may not be used, copied or transferred without the express written permission of Gram BioLine.

Manufactured by

Gram Commercial

Aage Grams Vej 1 · 6500 Vojens · Danmark

Tel: +45 73 20 13 00 · Fax: +45 73 20 13 01

e-mail: info@gram-bioline.com

www.gram-bioline.com

Gram Commercial, filial af Hoshizaki Europe BV, Holland



Before you proceed

Make sure to read the instructions for use through thoroughly before using the cabinet for the first time.

In the event of need for product support. Do not hesitate to contact us at: support@gram-bioline.com

Before You proceed

This instructions for use is intended for the following product series: **ExGuard**

We recommend that you read this instructions for use through thoroughly before using the cabinet for the first time. Gram Commercial does not guarantee safe operation if the cabinet is used for anything other than its intended use. Contents of the instructions for use can be subject to change without notice. No part of this instructions for use may be reproduced in any form without expressed written consent of Gram Commercial. Gram Commercial guarantees the cabinet under certain warranty conditions. Gram Commercial is not responsible for any loss or damage of content.

This instructions for use should be considered an integral part of the cabinet and should be stored close to the cabinet and be easy to access. If the instructions for use is lost, please refer to your local distributor or Gram Commercial for a replacement. For current versions of the instructions for use, please go www.gram-bioline.com.

Intended Use

Gram BioLine ExGuard cabinets are designed and manufactured for temperature-controlled storage of items potentially emitting noxious, malodourous and /or explosive atmospheres, where there is a risk that these atmospheres may pose a health hazard to the user and cabinet surroundings.

The user must ensure that the cabinet is used in accordance with its intended use. Abnormal use or use conflicting with the intended use or guidelines stipulated in the product documentation can lead to: danger to patient safety, damage to stored items, damage to cabinet, danger to user.

Symbols used throughout the instructions for use



Hazard



Risk of electric shock



Risk of material damage



Risk of personal injury



Risk of burning / freezing



Info



Risk of fire / flammable materials



Risk of explosion / explosive materials

Safety

Cabinet components

This part describes the main components pertinent to the user.



ATTENTION!

In the event of technical difficulties or breakdown, always contact Gram BioLine technical support or a Gram BioLine authorized service partner.

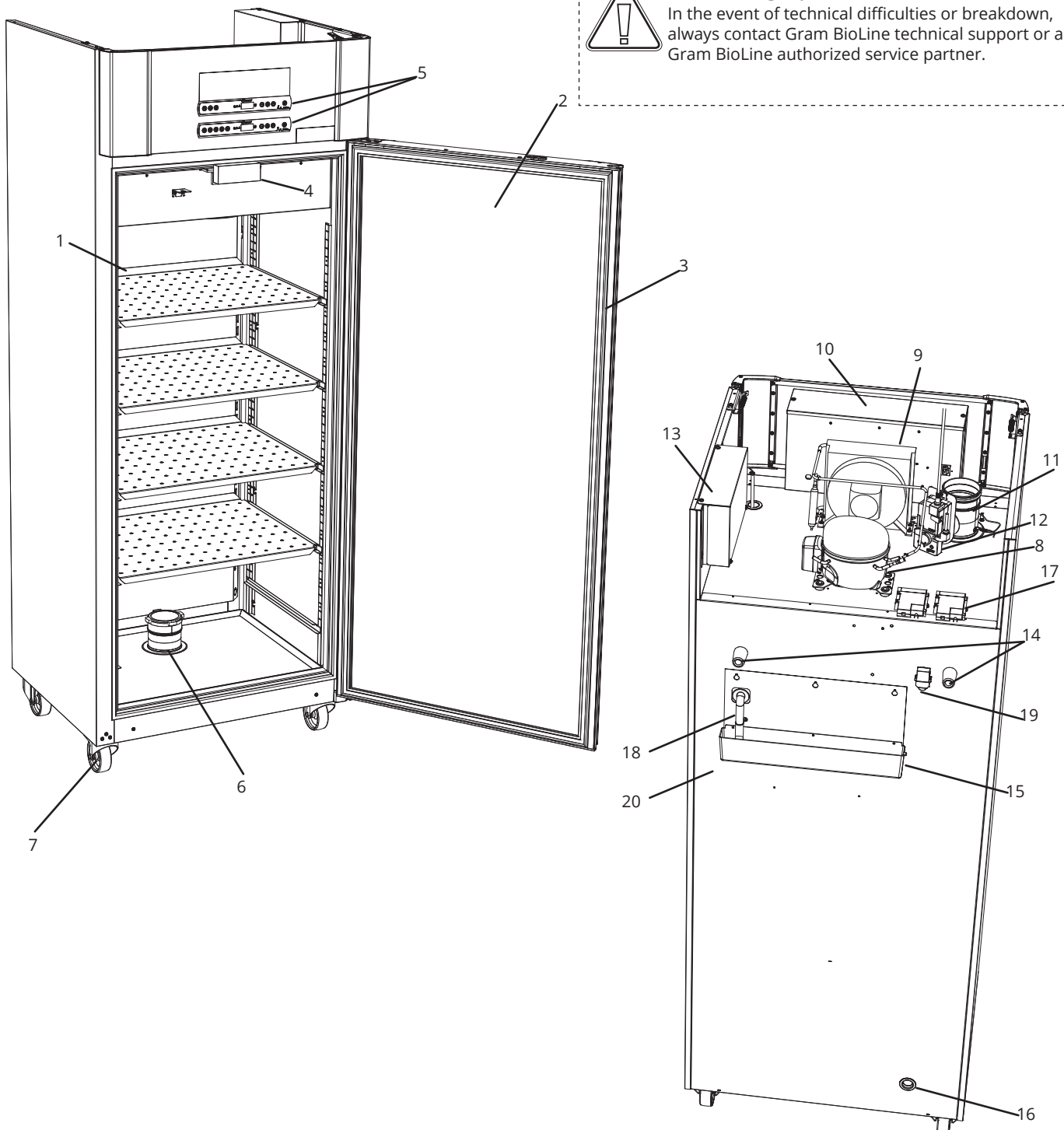

Cabinet components

This part describes the main components pertinent to the user.

- 1. Shelves and wall rails** - Ensure that the shelves are fixated according to this instructions for use instructs, before exerting load on them. All shelves or drawers must be supported by at least 2 shelf or drawer supports each.
- 2. Door** - Ensure that the door is closed completely after use. To minimize fluctuations in temperature, make the door openings as brief as possible.
- 3. Gasket for door** - Ensure that the gasket is pliable and in good working order. Keep clean, find instructions in this instructions for use.
- 4. Electromagnet for door-lock system** - Used to hold the door locked via the corresponding anchor-plate on the door and prevent access unless the extraction process is activated. **Ensure it does not show any sign of damage. If so, do not use cabinet and contact Gram BioLine or supplier for further aid.**
- 5. Digital displays for controllers** - Use the displays to show the cabinet temperature (lower one), the status of the extraction and door-lock system (upper) and, to set the parameters described in this instructions for use.
- 6. Inlet valve for exhaust** - Lets air into the cabinet during the extraction process. **Ensure it does not show any sign of damage. If so, do not use cabinet and contact Gram BioLine or supplier for further aid.**
- 7. Base of cabinet** - Can be legs or castors (as for this illustration). Ensure cabinets with legs are levelled properly and cabinets with castors are placed on a level surface and locked as mentioned in this instructions for use.
- 8. Compressor** - Ensure it's not dented or shows any other signs of damage.
- 9. Condenser and fan** - Like the compressor, ensure it's not dented or shows any other signs of damage.
- 10. Control box for refrigeration system** - Enclosure for controller, sensors and other parts that monitor and manage the refrigeration system. **Ensure it's not dented or shows any other signs of damage.**
- 11. Outlet valve for exhaust** - External connection point for ventilation to let hazardous and toxic fumes/vapours out of the cabinet during the extraction process. **Ensure it does not show any sign of damage. If so, do not use cabinet and contact Gram BioLine or supplier for further aid.**
- 12. Servo motor for exhaust** - Ensure the motor connection is properly connected and not lose or partly connected. **In the event of failure, do not use cabinet and contact Gram BioLine or supplier for further assistance.**
- 13. Control box for exhaust and door-lock system** - Enclosure for controller, sensors and other parts that monitor and manage the exhaust and door-lock systems. **Ensure it's not dented or shows any other signs of damage.**
- 14. Rubber spacers** - Are intended to ensure appropriate space between the cabinet and the wall. Do not remove.
- 15. Re-evaporator tray** - Ensure it's not cracked or shows any other signs of damage. It's recommended to clean it before applying power to the cabinet first time.
- 16. Access ports** - Used to lead sensors and similar into the cabinet. Ensure that the access port is sealed properly prior to start up.
- 17. Box for potential free contact** - Used to connect to an external alarm system. Instructions for connection is found in this instructions for use. Remember to set external alarms (EAL).
- 18. Defrost water tube** - This is the outlet for the defrost water coming from the evaporator tray inside the cabinet. Ensure its not damaged or shows sign of damage.
- 19. Equalisation valve** - Used to equalise pressure inside the cabinet when opening the door. Ensure its not damaged or shows sign of damage.
- 20. Equipotential Bonding** - To ensure compliance with ATEX regulations EN 60079-14. See installation section for specifications



ATTENTION - If parts show signs of damage; do not use cabinet and contact Gram BioLine or supplier for further aid.

Installation

Setting up

This part of the instructions for use describes how to set up the cabinet.



Due to safety and operating considerations, the cabinet must not be used outdoors. The cabinet should be installed in a dry and sufficiently ventilated area. To ensure efficient operation, the cabinet should not be installed in direct sunlight or close to heat sources.

NB. The cabinets optimal operating range is:

Cabinet	Minimum ambient operating temperature	Maximum ambient operating temperature
ER with solid door: +10/+43 °C	+10 °C	+43 °C
ER with glass door: +10/+38 °C	+10°C	+38 °C



Avoid placement of the cabinet in a chloric/acidic environment due to risk of corrosion.



The cabinet is shipped with a protective film that shall be removed prior to use.

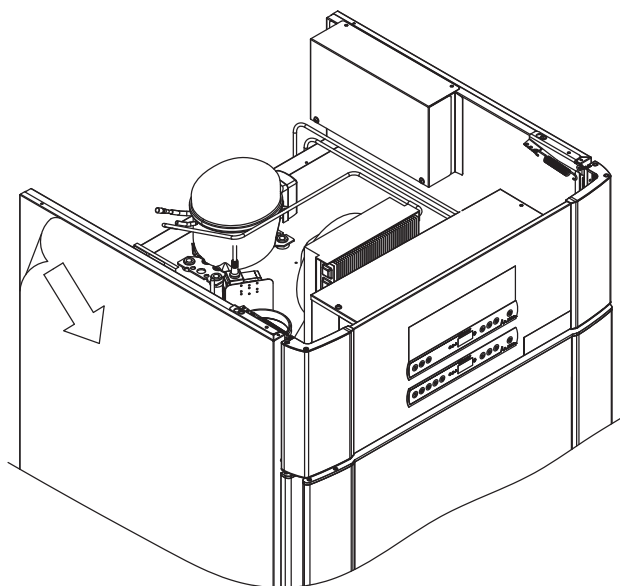

WARNING - POTENTIAL ELECTROSTATIC CHARGING

Removing protective film may cause electrostatic discharge.

Protective film must not be removed in ATEX zones.

This part of the instructions for use describes how to adjust legs / castors on the cabinet.

Cabinets equipped with legs should be levelled as shown in the illustration below.

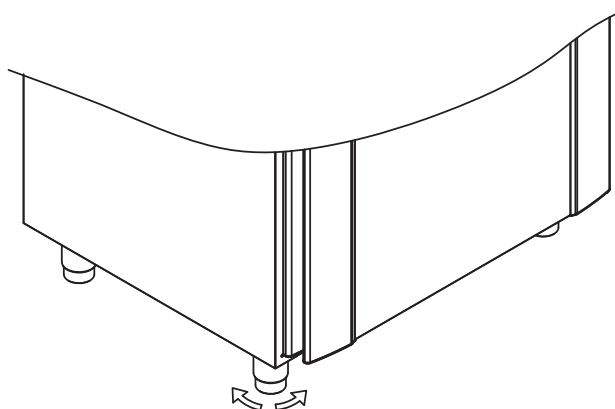

For cabinets equipped with casters, the floor must be level to ensure stable positioning and safe use. When the cabinet is positioned, the 2 front casters should be locked.

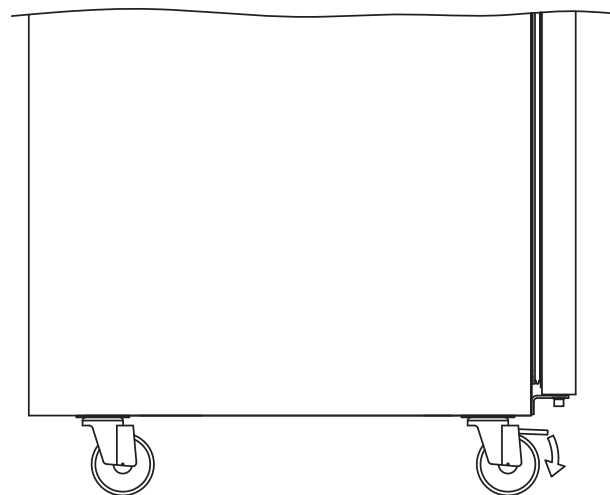

Clean the cabinet with a mild soap solution prior to use.



If the cabinet has been laying down (ex. during transport.). Then the cabinet must stand up-right for 24 hours prior to use, this enables oil in the compressor to run back into place.

Installation

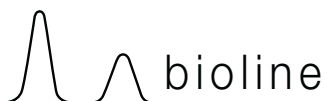

Anti tilt bracket



Cabinets with drawers and / or glass door must be secured to a stable vertical surface, ensuring that the cabinet cannot tip over when the drawers are drawn to the outermost position, or the door is open. Brackets for securing is included.

Find the instructions for the tilt bracket below.

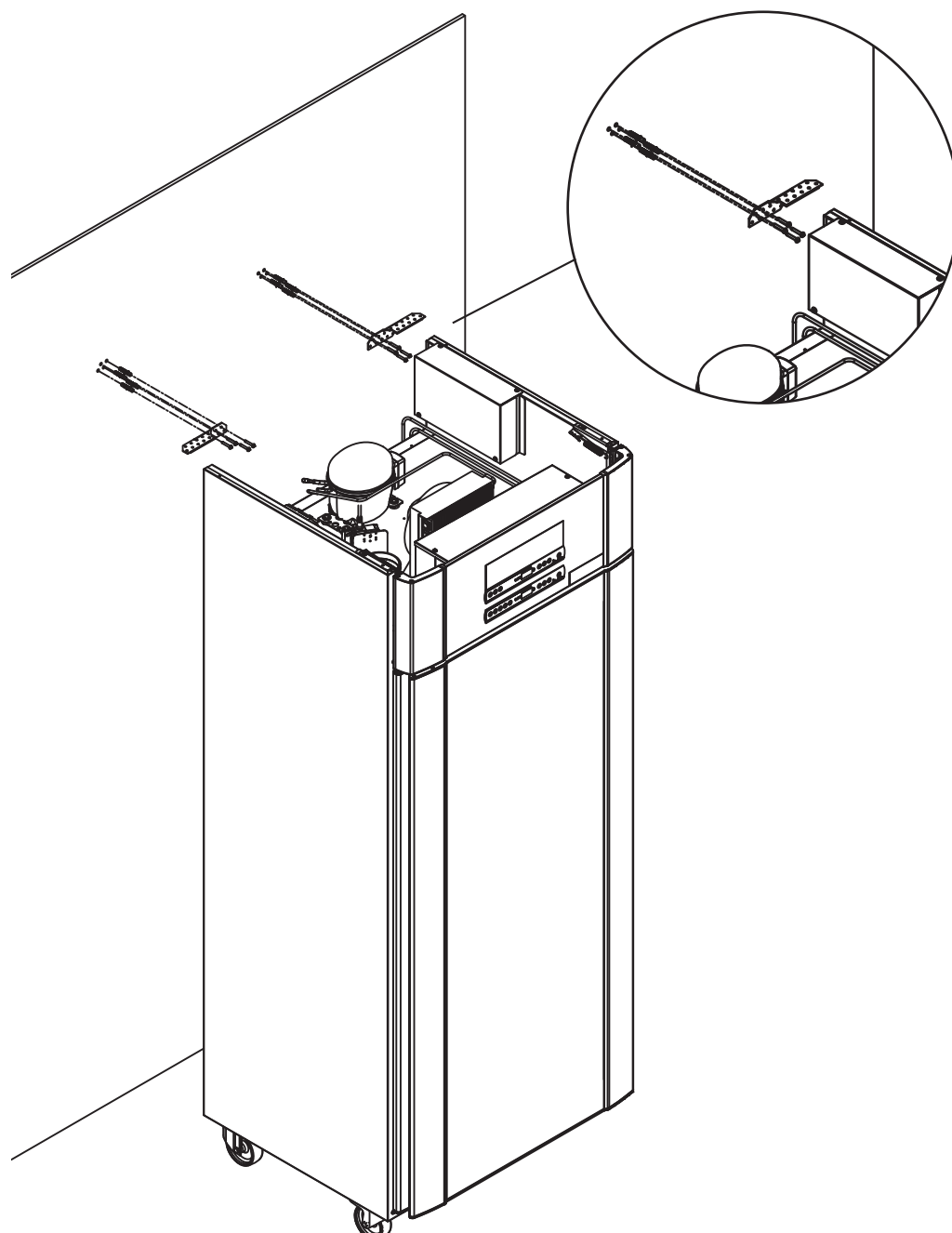

The tilt brackets must be fitted when installing the cabinet, ensuring that the users, surroundings and stored items are not damaged by the cabinet.

Installation

Setting up

The cabinet back should be placed as close to the wall as possible. Maximum allowed distance between wall and cabinet is 75 mm.

Max. 75 mm

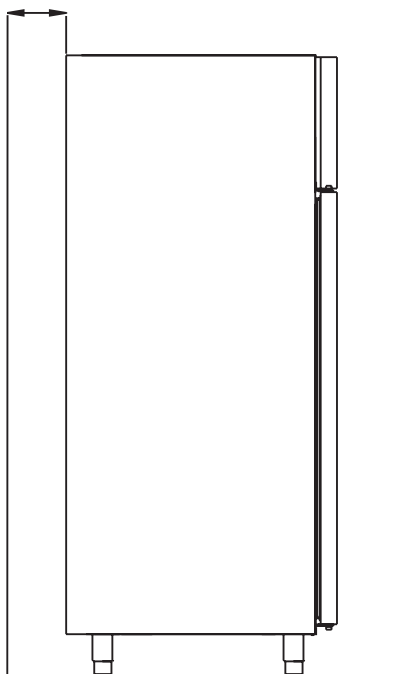

Do not cover the upper part of the cabinet if it has a top mounted compressor



Do not use electrical appliances inside the cabinet.



The cabinet is not suited for storing items that emit vapours which, either by themselves or in combination with other chemicals or water, may condensate and corrode the cabinet and its components.



All items in the cabinet that are not encapsulated, or wrapped, should be covered to reduce the risk of corrosion of the cabinet and its components.



FOR EX ENVIRONMENTS

Open containers inside the storage chamber may impact the ATEX zone classification



There must be at least a 30 mm gap between cabinets.

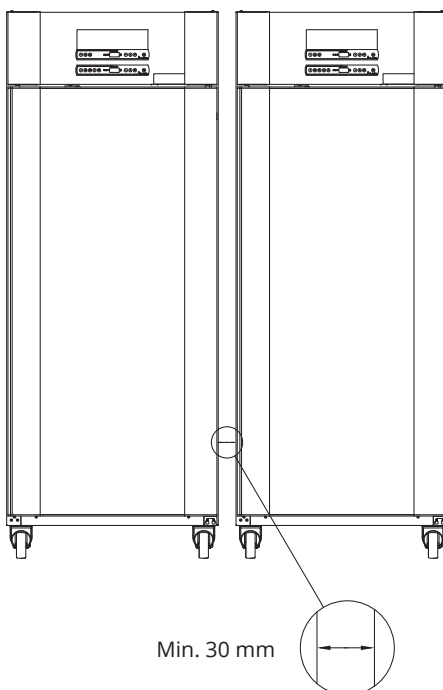

Min. 30 mm

Installation



Connection to ventilation system

The cabinet must not be taken into operation prior to connecting it to a dedicated ventilation system.

The ventilation must be fit for purpose in relation to use, the stored items and general installation conditions.

It is the responsibility of the user to ensure that the ventilation system is functional and providing adequate suction.

The connection assembly between the ventilation system ducting and cabinet must seal properly.

See illustration below for location of connection to the cabinet.



ATTENTION

Factory settings for; Extraction time (Damper Open time – “dot”), Extra extraction time (Extra Extraction – “EUE”) and Periodic Extraction frequency (Periodic Extraction – “PE”) must be assessed for adequacy and adjusted accordingly if required.

Stored items must be closed and sealed to minimise the potential concentration of noxious, malodorous and /or explosive atmospheres

REQUIREMENTS FOR INSTALLATION:

144 m³/h air flow per cabinet*

100 mm spiral ducting connection to ventilation system

* prerequisites: 600 L air change over 15 seconds, where the average speed is 5 m/s for Ø100 mm exhaust ducting.

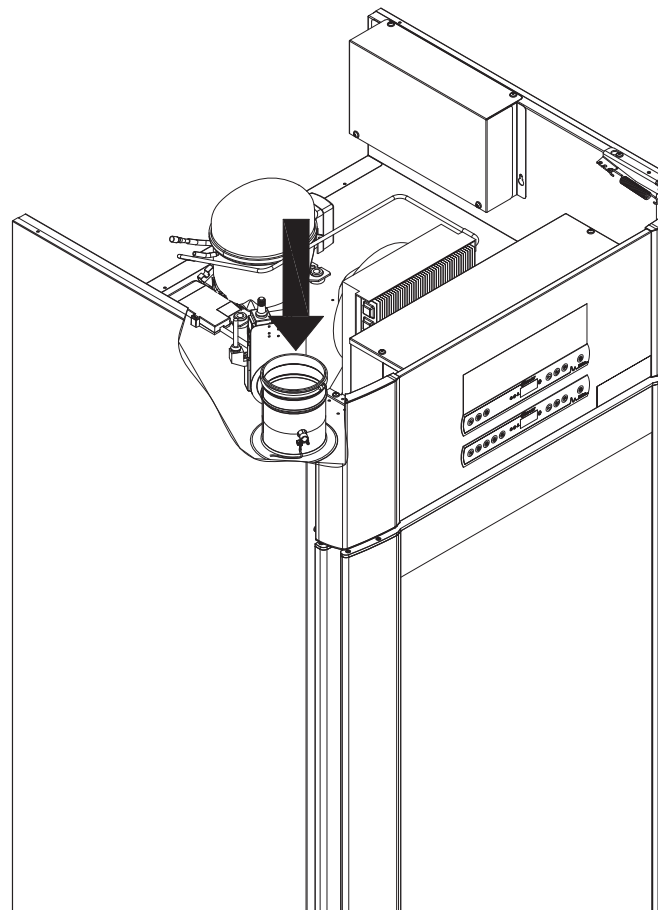

Please refer to EN 60079-14: Explosive atmospheres - Electrical installations design, selection and erection for installation requirements in an ATEX environment.

FOR EX ENVIRONMENTS



Special conditions for safe use may apply to this product when installing in an EN 60079-10 environment. Please see corresponding Ex certificate for specifications.

Installation

Voltage-free contact

This part of the instructions for use covers the voltage-free contact.

The illustration below shows the three connectors for the relay (used ex. in connecting to CTS or other external monitoring systems). The three connections, are respectively. Common, NO and NC.

The moment when voltage is applied the controller draws the relay, this makes it possible for the controller to respond to both high and low alarms, door alarms and power failures. Temperature alarms and door alarms must be configured in the external alarm settings (EAL) before they will activate the voltage-free contact. Find instructions on setting external alarms in the Parameter settings section.

The wires that are connected in the connection block for the voltage-free contact, are secured in place by the press-fit plate that is pressed onto the block, thereby also preventing access to the electrical circuit.

Connection of the voltage-free contact should be done by a qualified installer.

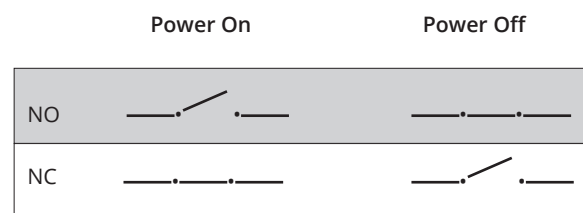
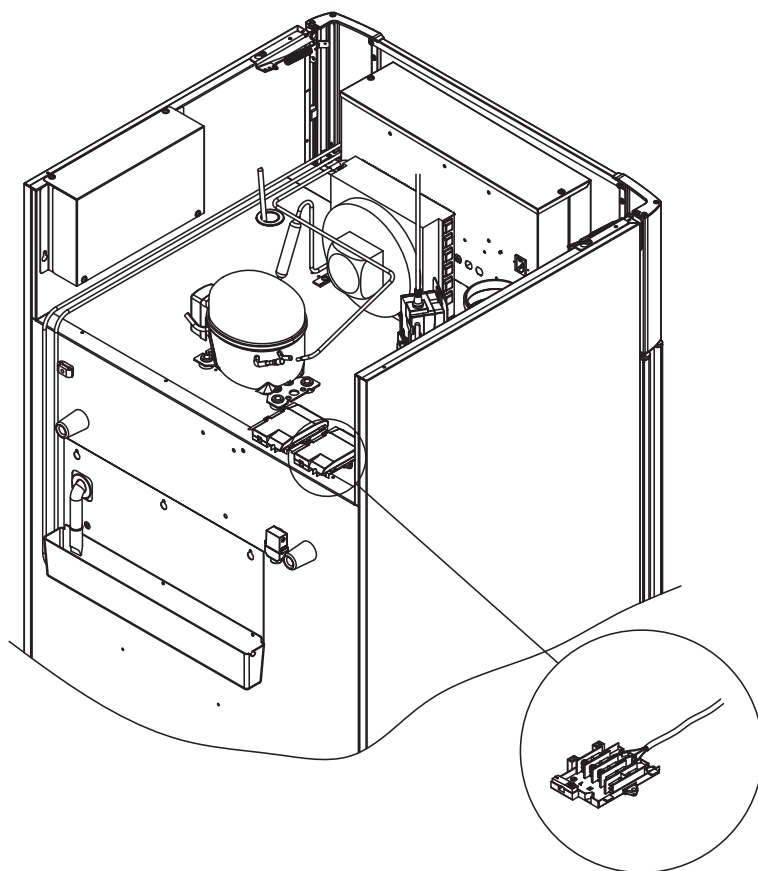

Connection to electricity

Read the following part thoroughly before connecting the cabinet. Contact an qualified electrician if in doubt.

When setting up in an ordinary scenario that is not subject to regulations for EN 60079-15 zone 2:

The appliance may be connected in accordance with applicable local heavy current regulations.



Note that there are special regulations for products that are in accordance with EN 60079-15 zone 2 and EN 60079-14: Explosive atmospheres - Electrical installations design, selection and erection.

The appliance has been manufactured in accordance with EN 60079-15: Electrical apparatus for explosive gas atmospheres - Part 15: Type of protection II 3G Ex ec nC ic IIB Tx Gc. Zone 2 is the applicable zone. If the appliance is to be installed in a zone 2 environment, specialist personnel should perform the installation, or be consulted beforehand, in order to ensure that the appliance is installed in compliance with the guidelines currently contained in the standard.

The cabinet is intended for connection to alternating current. The connection values for voltage (V) and frequency (Hz) are given on the type/number-plate.



The power cord from the mains is plugged in the terminal box on the back of the cabinet. The plug is then fixated in place by the hanger that is built into the terminal box. Please note that the hanger should be fitted tightly around the plug, as shown.

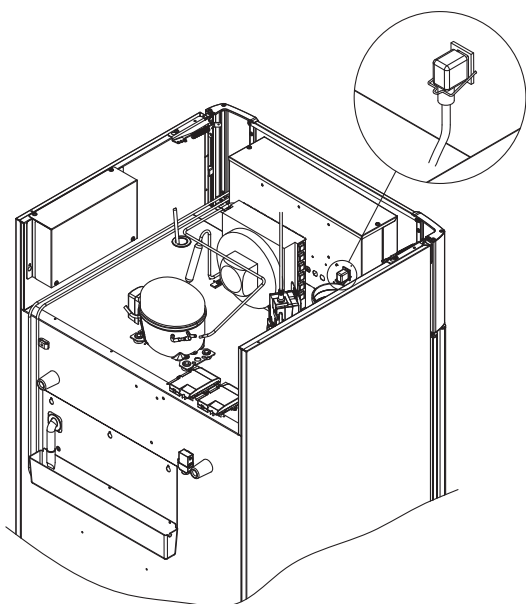

The appliance must be connected to the external power supply using a suitable device which mechanically prevents the plug and socket from being separated unintentionally. The connection must be labelled:

"DO NOT SEPARATE WHEN ENERGIZED"



IMPORTANT!

Fuses and similar must never be removed or replaced while the appliance is connected to a power source.

The electrical terminal box must never be opened while the appliance is connected to a power source.

The compressor starting equipment must never be dismantled while the appliance is connected to a power source.

The lighting must never be dismantled while the appliance is connected to a power source.

Whenever electrical components are dismantled or replaced, the appliance must be moved to an area in which there is no risk of ignition caused by the electrical components or gases contained in the appliance.

Never use the cabinet if the plug is damaged. The cabinet should be examined by a Gram BioLine service technician in such cases.

When setting up in an ordinary scenario that is not subject to regulations for Zone 2:

The appliance may be connected in accordance with applicable local heavy current regulations.

In both cases:

Use a three-wire plug, if the power outlet is intended for a three-wire plug, a the lead in green / yellow insulation should be connected to the ground terminal.

Power must be connected via a wall socket. The wall socket should be easily accessible.

All earthing requirements stipulated by the local electricity authorities must be observed. The cabinet plug and wall socket should then give correct earthing. If in doubt, contact your local supplier or authorized electrician.

In the event of technical difficulties or breakdown, always contact Gram BioLine technical support or a Gram BioLine authorized service partner. Never dismantle the terminal box or any other electrical component.

Installation

Frame earthing

This part of the instructions for use covers the frame earthing of the cabinet



- For installation in ATEX Cat. 3 Zone 2 areas, it is mandatory to have a redundant frame earthing, it is not sufficient to ground through the mains lead.
- To secure equipotential bonding of the unit – the mounted external bonding/ground connector must be used in accordance with national installation requirements e.g. EN 60079-14.
- The earthing wire should be black in colour and at least 4 mm² gauge, terminated with a ring terminal.
- Earthing of the cabinet is seen below.
- Mounting of the grounding wire should be done according to the following illustrations.
- Use the supplied machine screw and washer to attach the grounding wire to the cabinet. Tighten the machine screw to 3,2 Nm.
- Use a ring terminal to ensure secure bonding.
- Please find location for mounting on the back of the cabinet marked with "Attention: Equipotential bonding".

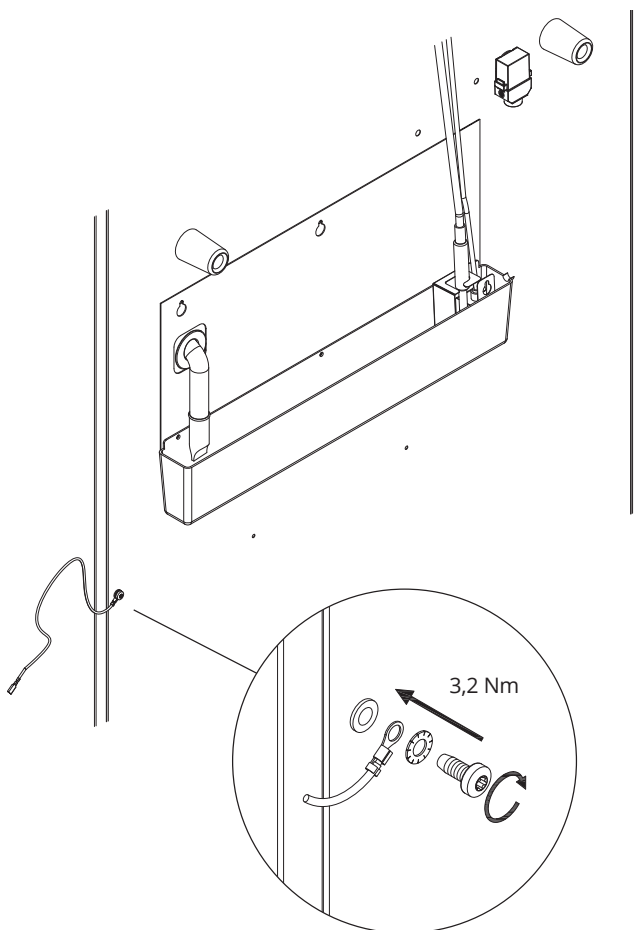

ATTENTION

Please note, this location is the only manufacturer-approved location for equipotential bonding.

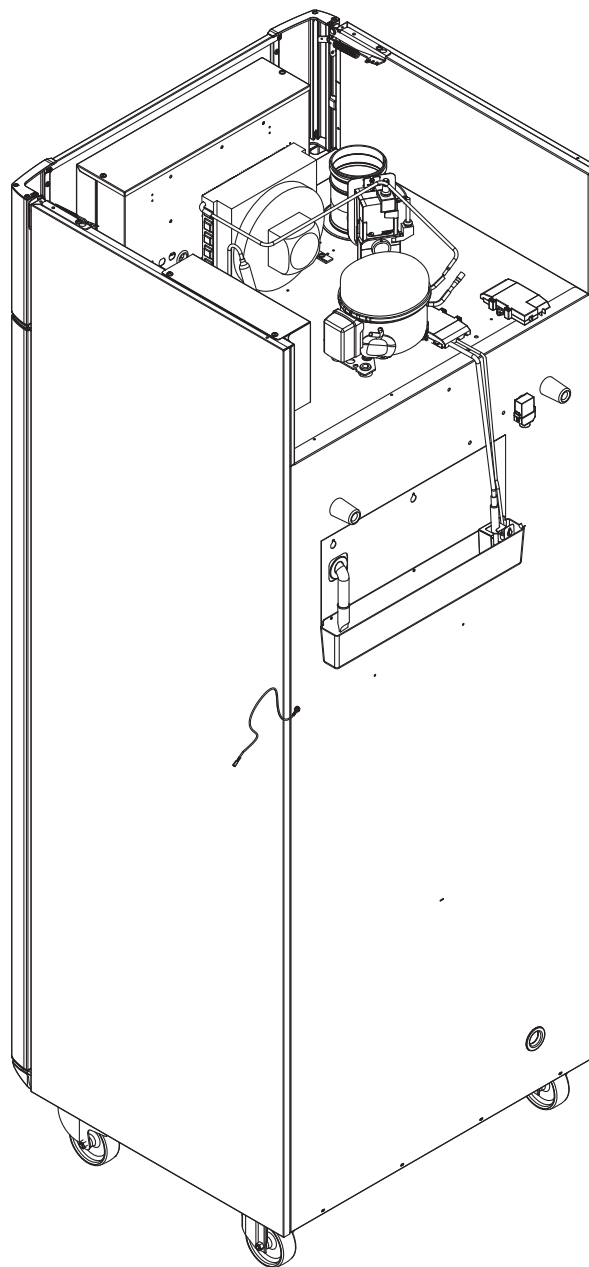

ExGuard control panels

Control panels

The following part describes the two control panels for the ExGuard

The ExGuard has two controls and therefore two control panels as can be seen on the drawing below.

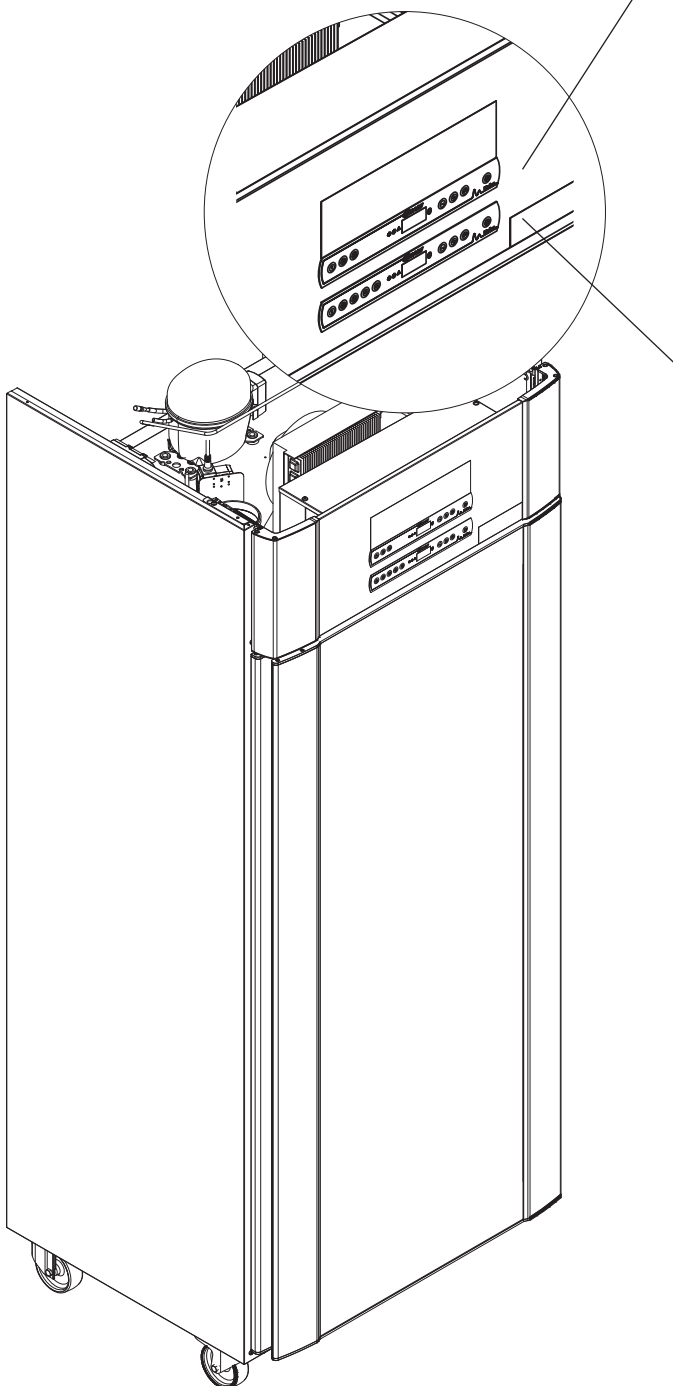

Extraction controller



The control panel for the extraction system is placed at the top of the of the control panel and has three keys to the left of the display (7 keys in total).

Please see page 32 to page 42 for details on the use and setting of the extraction system.

Operation controller



Bottom control panel is the interface for operating the refrigerator's own various functions and settings. This control panel has five keys to the left of the display.

Please see page 16 to page 31 for details on the use and setting of refrigeration system and alarms.

Start-up - conventional operation

The digital display (9 keys)

The digital display depicted below, shows the cabinets temperature and indicates if the cabinet is connected to a power source.

The following chapter explains the conventional operation of the cabinet and alarms for temperature, door etc.

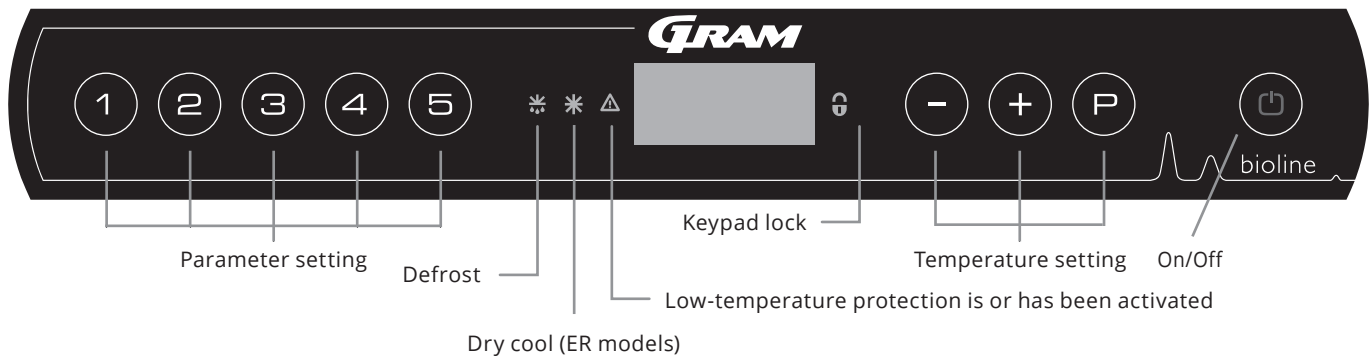

On / Off

Press to turn the cabinet On. Press for 6 seconds to turn the cabinet Off. The software version of the cabinet will be shown when turning the cabinet On, followed by the software variant and a display test.

The cabinet is ready when the temperature is displayed. The cabinet will automatically start a defrost-cycle when turned on, and terminate it again after a system check.

The cabinet will always commence operation when initially connected to a power supply. For instance after a power outage or when plugging the cabinet in for the first time.

- Parameter setting - Gives access to the cabinets configurable parameters.
- Defrost - Defrost in progress
- Dry cool - Dry cool in progress (ER-models)
- Keypad lock - Keypad is locked, no access to functions or menus
- Temperature setting - Setting of temperature setpoint and navigation in the menus
- On / Off - Turn the cabinet On or Off, and navigation in the menus



Make sure the appliance is switched Off at the socket before service is performed on electrical parts. It is not sufficient to switch Off the cabinet on the key, as current will persist in some electrical parts of the cabinet.

WARNING!

DO NOT OPEN, MAINTAIN OR SERVICE IN AN AREA WHEN AN EXPLOSIVE ATMOSPHERE IS PRESENT



High and low temperature alarms set up in the cabinets' controller (including EAL alarms) must be accompanied by additional redundant independent external alarms to ensure maximum item safety.

Temperature setting

Temperature adjustments are done by holding and pressing either or . Confirm the settings by letting go of the buttons.

All-round introduction to navigating the menu

Beyond setting the temperature and On/Off, , , and are used to navigate the menu and set the parameters of the cabinet.

The buttons have following functions in the menu:

- - Open a menu step / confirm a set value in the parameter settings.
- - Scroll upwards in a given menu / raise a given value in parameter settings (alarm setpoint for instance).
- - Scroll downwards in a given menu / lower a given value in parameter settings.
- - Go a menu step back.

Walkthrough of menu

The menu below gives a quick overview of the parameter settings for the cabinet.

User menu

Menu Access (P) + (1) →	↓	→		
	dC*			
Local alarm settings	LAL	LHL	[° C]	Upper alarm limit. Code for activated alarm [A2]
		LLL	[° C]	Lower alarm limit. Code for activated alarm [A3]
		LHd	[Min.]	Delay of upper alarm limit
		LLd	[Min.]	Delay of lower alarm limit
		dA	On/ Off	Door alarm. Code for activated alarm [A1]. [1=On / 0=Off]
		dAd	[Min.]	Delay of door alarm
		bU	On/ Off	Acoustic signal for alarm codes [A1], [A2] and [A3]. [1=On / 0=Off]
External alarm settings	EAL	EHL	[° C]	Upper alarm limit. Code for activated alarm [A4]
		ELL	[° C]	Lower alarm limit. Code for activated alarm [A5]
		EHd	[Min.]	Delay of upper alarm limit
		ELd	[Min.]	Delay of lower alarm limit
		dA	On/ Off	Door alarm. Code for activated alarm [A1]. [1=On / 0=Off]
		dAd	[Min.]	Delay of external door alarm
		bU	On/ Off	Acoustic signal for external alarm codes [A1], [A4], [A5]. [1=On / 0=Off]
Offset of sensors	CAL	CA	[° K]	Calibration of A-sensor. Reference sensor for the refrigeration system
		CE	[° K]	Calibration of E-sensor. Reference sensor for the display and alarms
		ALL		Activation of escorted alarm limits. [FAS]= locked limits / [ESC] = follows setpoint
		dEF		Number of defrosts per 24 hours (4 is factory setting)
		dPS		Reference sensor for the display (A, E or F) (E is factory setting)

* Only ER-models: Dry cooling - dC - [HO=Off/H1= On].

Other shortcuts

Buttons:	Duration:	Function:
(P) + (0)	> 3 seconds	Start or stop a defrost
(0) + (1)	> 6 seconds	Activating / deactivating the keypad lock
(P)	-	Shows temperature setpoint value
(+)	-	Shows the highest registered temperature spike (since the last clear and reset alarm history)
(-)	-	Shows the lowest registered temperature spike (since the last clear and reset alarm history)
(+) + (-)	> 3 seconds	Clear and reset alarm history
(P) + (1) + (0)	> 6 seconds	Reset of set parameters. Restores factory settings
(P) + (1)	> 3 seconds	Access to user menu and alarm settings

Error codes

The following table covers the different error codes that might occur.

Display code:	Explanation:
- 0 -	Door is open
A1	Door alarm "dAd" from LAL and/or EAL has been activated
A2	Local upper alarm LHL is or has been activated
A3	Local lower alarm LLL is or has been activated
A4	External upper alarm EHL is or has been activated
A5	External lower alarm ELL is or has been activated
F1	Error on the main cabinet sensor. The refrigeration system will use an emergency program to make the cabinet run. Temperature stability will be affected. Service is required
F2	Error on the evaporator sensor. Service is required
F3	Error on the 1. condenser sensor. Service is required
F4	Error on the 2. condenser sensor. Service is required
F5	Error on the extra sensor. Service is required
F7	F7 indicates that the temperature of the condenser is too high. Turn Off the cabinet and check that the condenser is not covered by undesirable items, and insure that the condenser (and possibly filter) is clean. Service is required if the problem is not alleviated

Cancelling an acoustic alarm

Cancelling a door alarm: [A1] flashes in the display. Press P to cancel.

Cancelling a temperature alarm: [A2, A3] Flashes in the display. Press P to cancel.

The display will continue to flash if the temperature is outside the alarm limits, and will continue until the temperature has recovered.

Reading the alarm history - Example [A2]

[A2] flashes in the display - This means that the temperature has exceeded the set value for the upper temperature limit, LHL.

Press P to cancel the [A2]. The display continues to flash, indicating that there is information in the alarm history. Press + ,

Htt (High temperature time) is shown, press P to see for how long the temperature was above the set alarm limit. Press + to return to Htt. Press + to reach Ht (Highest temperature). Press P to read the highest recorded temperature during Htt. Press + to return to Ht and press + again to leave the alarm history function.

The procedure for reading an [A3] alarm is identical, apart from entering the alarm history with - . When reading out temperatures below set limits, the parameters are Ltt and Lt.

A flashing display with no alarm codes indicates that the alarm codes have been cancelled, but the alarm history contains information.

Dry cool



The following part covers activation / deactivation of the dry cool feature (only applicable to ER models).

dC - Setting the dry cool feature

- ↳ Press and hold P + 1 for more than 3 seconds
- ↳ Press P to choose "dC"
- ↳ Press + or - to choose between [H1= Off] [H0=On]
- ↳ Press P to confirm
- ↳ Leave the user menu by pressing P , press several times until the cabinet temperature is shown in the display.

Please note that the dry cool feature reduces that relative humidity in the cabinet, but does not control it.

Furthermore, please note that activation of the dry cool feature can cause greater fluctuations in the cabinet temperature during defrost.

Local alarm settings

Local high alarm

The following part covers the setting of upper and lower temperature alarm limits.

Local low alarm

LHL - Setting the upper alarm limit [° C]

- ↳ Press and hold (P) + (1) for more than 3 seconds
- ↳ Press (+) to proceed to "LAL"
- ↳ Press (P) to select "LAL". "LHL" is now shown in the display
- ↳ Press (P) to select "LHL". The upper alarm limit is now shown in the display
- ↳ Press (+) or (-) to set the desired value for the upper alarm limit
- ↳ Press (P) to confirm the set value

- The upper alarm limit is now set, proceed to other parameters by pressing (⏪), and then navigate by using (+) or (-).

- ↳ Leave the user menu by pressing (⏪) several times until the cabinet temperature is shown in the display

LLL - Setting the lower alarm limit [° C]

- ↳ Press and hold (P) + (1) for more than 3 seconds
- ↳ Press (+) to proceed to "LAL"
- ↳ Press (P) to select "LAL". "LHL" is now shown in the display
- ↳ Press (+) to proceed to "LLL"
- ↳ Press (P) to select "LLL". The lower alarm limit is now shown in the display
- ↳ Press (+) or (-) to set the desired value for the lower alarm limit
- ↳ Press (P) to confirm the set value

- The lower alarm limit is now set, proceed to other parameters by pressing (⏪), and then navigate by using (+) or (-).

- ↳ Leave the user menu by pressing (⏪) several times until the cabinet temperature is shown in the display



ATTENTION

High and low temperature alarms set up in the cabinets' controller (including EAL alarms) must be accompanied by additional redundant independent external alarms to ensure maximum item safety.

Local high alarm delay

The following part covers the setting of the delay for the local upper and lower temperature alarm limits.

Local low alarm delay

LHd - Setting the delay of the local upper alarm limit [min.]

- ↳ Press and hold $\text{P} + \text{1}$ for more than 3 seconds
 - ↳ Press + to proceed to "LAL"
 - ↳ Press P to select "LAL". "LHL" is now shown in the display
 - ↳ Press + several times until "LHd" is shown in the display
 - ↳ Press P to select "LHd". The delay of the upper alarm limit is now shown in the display
 - ↳ Press + or - to set the desired value for the delay of the upper alarm limit
 - ↳ Press P to confirm the set value
- The delay of the upper alarm limit is now set, proceed to other parameters by pressing E , and then navigate by using + or - .
- ↳ Leave the user menu by pressing E several times until the cabinet temperature is shown in the display

LLd - Setting the delay of the local lower alarm limit [min.]

- ↳ Press and hold $\text{P} + \text{1}$ for more than 3 seconds
 - ↳ Press + to proceed to "LAL"
 - ↳ Press P to select "LAL". "LHL" is now shown in the display
 - ↳ Press + several times until "LLd" is shown in the display
 - ↳ Press P to select "LLd". The delay of the lower alarm limit is now shown in the display
 - ↳ Press + or - to set the desired value for the delay of the lower alarm limit
 - ↳ Press P to confirm the set value
- The delay of the lower alarm limit is now set, proceed to other parameters by pressing E , and then navigate by using + or - .
- ↳ Leave the user menu by pressing E several times until the cabinet temperature is shown in the display



ATTENTION

High and low temperature alarms set up in the cabinets' controller (including EAL alarms) must be accompanied by additional redundant independent external alarms to ensure maximum item safety.

On / Off local door alarm

The following part covers the setting of the door alarm and the delay of the door alarm.

Delay for local door alarm

dA - Activate / deactivate of local door alarm

- ↳ Press and hold $\text{P} + \text{1}$ for more than 3 seconds
 - ↳ Press + to proceed to "LAL"
 - ↳ Press P to select "LAL". "LHL" is now shown in the display
 - ↳ Press + several times until "dA" is shown in the display
 - ↳ Press P to select "dA".
 - ↳ Press + or - to activate / deactivate the local door alarm [1 = activated / 0 = deactivated]
 - ↳ Press P to confirm the set value
- The local door alarm is now configured, proceed to other parameters by pressing E , and then navigate by using + or - .
- ↳ Leave the user menu by pressing E several times until the cabinet temperature is shown in the display

dAd - Setting the delay of the local door alarm [min.]

- ↳ Press and hold $\text{P} + \text{1}$ for more than 3 seconds
 - ↳ Press + to proceed to "LAL"
 - ↳ Press P to select "LAL". "LHL" is now shown in the display
 - ↳ Press + several times until "dAd" is shown in the display
 - ↳ Press P to select "dAd". The delay of the local door alarm is now shown in the display
 - ↳ Press + or - to set the desired value for the delay of the local door alarm
 - ↳ Press P to confirm the set value
- The delay of the local door alarm is now configured, proceed to other parameters by pressing E , and then navigate by using + or - .
- ↳ Leave the user menu by pressing E several times until the cabinet temperature is shown in the display



ATTENTION

High and low temperature alarms set up in the cabinets' controller (including EAL alarms) must be accompanied by additional redundant independent external alarms to ensure maximum item safety.

Local acoustic settings

The following part covers the setting of the acoustic local alarms.

bU - Activation / deactivation of the acoustic local alarms

- ↳ Press and hold $\text{P} + \text{1}$ for more than 3 seconds
 - ↳ Press + to proceed to "LAL"
 - ↳ Press P to select "LAL". "LHL" is now shown in the display
 - ↳ Press + several times until "bU" is shown in the display
 - ↳ Press P to select "bU".
 - ↳ Press + or - to activate / deactivate the local acoustic alarms [1 = activated / 0 = deactivated]
 - ↳ Press P to confirm the set value
- The local acoustic alarms is configured, proceed to other parameters by pressing E , and then navigate by using + or - .
- ↳ Leave the user menu by pressing E several times until the cabinet temperature is shown in the display



ATTENTION

High and low temperature alarms set up in the cabinets' controller (including EAL alarms) must be accompanied by additional redundant independent external alarms to ensure maximum item safety.

External alarm settings

External high alarm

The following part covers the setting of upper and lower external temperature alarm limits.

External low alarm

EHL - Setting the external upper alarm limit [° C]

- ↳ Press and hold $\text{P} + \text{1}$ for more than 3 seconds
 - ↳ Press + several times until "EAL" is shown in the display
 - ↳ Press P to select "EAL". "EHL" is now shown in the display
 - ↳ Press P to select "EHL". The external upper alarm limit is now shown in the display
 - ↳ Press + or - to set the desired value for the external upper alarm limit
 - ↳ Press P to confirm the set value
- The external upper alarm limit is now set, proceed to other parameters by pressing ⏏ , and then navigate by using + or - .
- ↳ Leave the user menu by pressing ⏏ several times until the cabinet temperature is shown in the display

ELL - Setting the external lower alarm limit [° C]

- ↳ Press and hold $\text{P} + \text{1}$ for more than 3 seconds
 - ↳ Press + several times until "EAL" is shown in the display
 - ↳ Press P to select "EAL". "EHL" is now shown in the display
 - ↳ Press + to proceed to "ELL"
 - ↳ Press P to select "ELL". The external lower alarm limit is now shown in the display
 - ↳ Press + or - to set the desired value for the external lower alarm limit
 - ↳ Press P to confirm the set value
- The external lower alarm limit is now set, proceed to other parameters by pressing ⏏ , and then navigate by using + or - .
- ↳ Leave the user menu by pressing ⏏ several times until the cabinet temperature is shown in the display



ATTENTION

High and low temperature alarms set up in the cabinets' controller (including EAL alarms) must be accompanied by additional redundant independent external alarms to ensure maximum item safety.

External high alarm delay

External low alarm delay

The following parts covers the setting of the delay of the external upper and lower alarms.

EHD - Setting the delay of the external upper alarm limit [min.]

- ↳ Press and hold $\text{P} + \text{1}$ for more than 3 seconds
 - ↳ Press + to proceed to "EAL"
 - ↳ Press P to select "EAL". "EHL" is now shown in the display
 - ↳ Press + several times until "EHD" is shown in the display
 - ↳ Press P to select "EHD". The external delay of the upper alarm limit is now shown in the display
 - ↳ Press + or - to set the desired value for the external delay of the upper alarm limit
 - ↳ Press P to confirm the set value
- The delay of the external upper alarm limit is now set, proceed to other parameters by pressing E , and then navigate by using + or -
- ↳ Leave the user menu by pressing E several times until the cabinet temperature is shown in the display

ELd - Setting the delay of the external lower alarm limit [min.]

- ↳ Press and hold $\text{P} + \text{1}$ for more than 3 seconds
 - ↳ Press + to proceed to "EAL"
 - ↳ Press P to select "EAL". "EHL" is now shown in the display
 - ↳ Press + several times until "ELd" is shown in the display
 - ↳ Press P to select "ELd". The delay of the external lower alarm limit is now shown in the display
 - ↳ Press + or - to set the desired value for the delay of the lower alarm limit
 - ↳ Press P to confirm the set value
- The delay of the external lower alarm limit is now set, proceed to other parameters by pressing E , and then navigate by using + or -
- ↳ Leave the user menu by pressing E several times until the cabinet temperature is shown in the display



ATTENTION

High and low temperature alarms set up in the cabinets' controller (including EAL alarms) must be accompanied by additional redundant independent external alarms to ensure maximum item safety.

On/Off external door alarm

External door alarm delay

The following parts covers the setting and delay, of the external door alarm.

dA - Activation / deactivation of external door alarm

- ↳ Press and hold $\text{P} + \text{1}$ for more than 3 seconds
 - ↳ Press + to proceed to "EAL"
 - ↳ Press P to select "EAL". "EHL" is now shown in the display
 - ↳ Press + several times until "dA" is shown in the display
 - ↳ Press P to select "dA"
 - ↳ Press + or - to activate / deactivate the external door alarm [1 = activated / 0 = deactivated]
 - ↳ Press P to confirm the set value
- The external door alarm is now configured, proceed to other parameters by pressing P , and then navigate by using + or - .
- ↳ Leave the user menu by pressing P several times until the cabinet temperature is shown in the display

dAd - Setting the delay of the external door alarm [min.]

- ↳ Press and hold $\text{P} + \text{1}$ for more than 3 seconds
 - ↳ Press + to proceed to "EAL"
 - ↳ Press P to select "EAL". "EHL" is now shown in the display
 - ↳ Press + several times until "dAd" is shown in the display
 - ↳ Press P to select "dAd". The delay of the external door alarm is now shown in the display
 - ↳ Press + or - to set the desired value for the delay of the external door alarm
 - ↳ Press P to confirm the set value
- The delay of the external door alarm is now configured, proceed to other parameters by pressing P , and then navigate by using + or - .
- ↳ Leave the user menu by pressing P several times until the cabinet temperature is shown in the display



ATTENTION

High and low temperature alarms set up in the cabinets' controller (including EAL alarms) must be accompanied by additional redundant independent external alarms to ensure maximum item safety.

External acoustic settings

The following part covers the setting of the acoustic external alarms.

bU - Activation / deactivation of the acoustic external alarms

- ↳ Press and hold $\text{P} + \text{1}$ for more than 3 seconds
 - ↳ Press + to proceed to "EAL"
 - ↳ Press P to select "EAL". "EHL" is now shown in the display
 - ↳ Press + several times until "bU" is shown in the display
 - ↳ Press P to select "bU"
 - ↳ Press + or - to activate / deactivate the external acoustic alarms [1 = activated / 0 = deactivated]
 - ↳ Press P to confirm the set value
- The external acoustic alarms is configured, proceed to other parameters by pressing E , and then navigate by using + or - .
- ↳ Leave the user menu by pressing E several times until the cabinet temperature is shown in the display



ATTENTION

High and low temperature alarms set up in the cabinets' controller (including EAL alarms) must be accompanied by additional redundant independent external alarms to ensure maximum item safety.

Parameter settings

Sensor offset

The temperature sensors connected to the controller can be offset independently of each other in the parameter cAL.

Offset is used in cases where there are deviations in the cabinets actual operation compared to the display and / or control measurements by independent temperature monitoring.

The cabinet is equipped with a A-sensor and an extra sensor E-sensor.

The A-sensor is used to manage the cabinets refrigeration system and is fixated in a given position in the cabinet, not in storage space. The location of the A sensor must not be altered.

The E-sensor is placed in the cabinet storage space and can be moved around in the cabinet to get the desired reference point for temperature. The E-sensor is the default display sensor and reference for the alarms. The E-sensor has no effect on control of the refrigeration system.

The A-sensor should be offset if the actual temperature in the cabinet does not match the setpoint, despite taking the hysteresis into consideration. Offset of A sensor is named "cA".

The E-sensor should be offset if the actual temperature in the cabinets display, provided that the display sensor for reference is the E-sensor, does not match the independent temperature monitoring used for control. Offset of E-sensor is named "cE"

Practical example of offset:

Example 1 - The temperature in the cabinet is operating colder than the actual setpoint.

With a setpoint of +4°C, the actual temperature inside the cabinet is between +2 and +4°C. The desired temperature range is between +3 and +5°C. This means that "cA", in this case, should be -1,0K, so that the refrigeration system stops 1,0K before and starts 1,0K later than the setpoint normally otherwise would dictate.

Example 2 - The temperature in the cabinet is operating warmer than the actual setpoint.

With a setpoint of +4°C, the actual temperature inside the cabinet is between +4 and +6°C. The desired temperature range is between +3 and +5°C. This means that "cA", in this case, should be 1,0K, so that the refrigeration system stops 1,0K later and starts 1,0K earlier than the setpoint normally otherwise would dictate.

Sensor offset

Offset of the A-sensor

- ↳ Press and hold $\text{P} + \text{1}$ for more than 3 seconds
 - ↳ Press + several times until "cAL" is shown in the display
 - ↳ Press P to select "cAL". "cA" is shown in the display
 - ↳ Press P to select "cA"
 - ↳ Press + or - to offset the A-sensor
 - ↳ Press P to confirm the set value
- The A-sensor is now offset, proceed to other parameters by pressing M , and then navigate by using + or -
- ↳ Leave the user menu by pressing M several times until the cabinet temperature is shown in the display

Offset of the E-sensor

- ↳ Press and hold $\text{P} + \text{1}$ for more than 3 seconds
 - ↳ Press + several times until "cAL" is shown in the display
 - ↳ Press P to select "cAL". "cA" is shown in the display
 - ↳ Press + until "cE" is shown in the display
 - ↳ Press P to select "cE"
 - ↳ Press + or - to offset the E-sensor
 - ↳ Press P to confirm the set value
- The E-sensor is now offset, proceed to other parameters by pressing M , and then navigate by using + or -
- ↳ Leave the user menu by pressing M several times until the cabinet temperature is shown in the display

Escorted / set alarm limits

The following part covers the setting of escorted or set alarm limits.

ALL - Setting of escorted / set alarm limits

- ↳ Press and hold $\text{P} + \text{1}$ for more than 3 seconds
- ↳ Press + several times until "ALL" is shown in the display
- ↳ Press P to select "ALL"
- ↳ Press + or - to select set or escorted alarm limits
- ↳ Press P to confirm the set value
- ↳ Leave the user menu by pressing ⏏ several times until the cabinet temperature is shown in the display

"Set alarm" is fixed limits working independently from the setpoint. The alarm limits will remain the selected values regardless of the setpoint being altered.

"Escorted alarm" is fixed limits locked to the setpoint. The alarm limits will change according to the altered setpoint.

Defrosts / 24 hours

The following part covers the setting of the amount of defrosts per 24 hours.

dEF - Number of defrosts

- ↳ Press and hold $\text{P} + \text{1}$ for more than 3 seconds
- ↳ Press + several times until "dEF" is shown in the display
- ↳ Press P to select "dEF"
- ↳ Press + or - to set the desired amount of defrosts per 24 hours (factory setting is 4)
- ↳ Press P to confirm the set value
- ↳ Leave the user menu by pressing ⏏ several times until the cabinet temperature is shown in the display



Please note: It is very important that defrosts should not be set to 0 for a prolonged period of time, as this will reduce the cooling capacity of the cabinet.

Display sensor

The following part covers the setting of which sensor to be shown in the display.

dPS - Selection of reference sensor for the display

- ↳ Press and hold **(P)** + **(1)** for more than 3 seconds
- ↳ Press **(+)** several times until "dPS" is shown in the display
- ↳ Press **(P)** to select "dPS"
- ↳ Press **(+)** or **(-)** to select either the A- or E-sensor
- ↳ Press **(P)** to confirm the set value
- ↳ Leave the user menu by pressing **(⏏)** several times until the cabinet temperature is shown in the display



Please note that dPS only changes the reference sensor for the display, and not the reference sensor for the alarms.



Furthermore, please note that the reference sensor for the refrigeration system is the A-sensor, this can not be altered.

Start-up ExGuard

The digital display (7 keys)

The digital display depicted below, shows the ExGuards door lock and extraction system and indicates if the cabinet is connected to a power source.

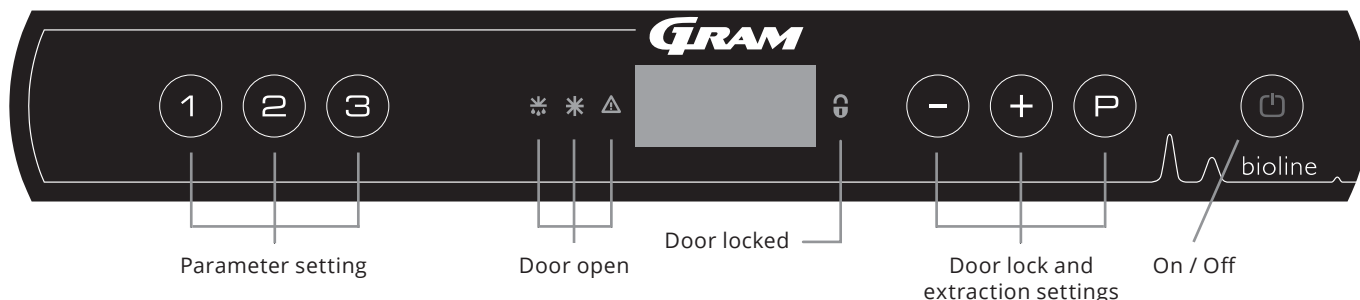

All-round introduction to navigating the menu for the extraction system

Beyond setting the door lock and extraction system and On/Off,

(P), (+), (-) and (⏪) is used to navigate the menu and set the parameters of the ExGuard.

The buttons have following functions in the menu:

(P) - Open a menu step / confirm a set value in the parameter settings.

(+) - Scroll upwards in a given menu / raise a given value in parameter settings (alarm setpoint for instance).

(-) - Scroll downwards in a given menu / lower a given value in parameter settings.

(⏪) - Go a menu step back. The key has no other function than return when operating the menu.

The cabinet is ready when the temperature is displayed.

During start-up and operation the display is blank, unless extraction process or alarms are activated or the menu is entered.

- Parameter setting - Gives access to the ExGuards configurable parameters for the door lock and extraction system.
- Door open - Green LED's lighting up and indicating the door-lock is released.
- Display - Indicates status of the door lock and extraction system when it is activated and shows menu points when navigating with right side digits (-, + og P). If the menu is not active the display is blank.
- Door closed - Red LED lighting up when door lock is active.
- Door lock setting - Setting of door lock and extraction setpoints and navigation in the menus.
- On / Off - Used for navigation in the menus



Make sure the appliance is switched Off at the socket before service is performed on electrical parts. It is not sufficient to switch Off the cabinet on the (⏪) key, as current will persist in some electrical parts of the cabinet.

WARNING!

DO NOT OPEN, MAINTAIN OR SERVICE IN AN AREA WHEN AN EXPLOSIVE ATMOSPHERE IS PRESENT

Start-up ExGuard



Walkthrough of menu

The menu below gives an overview of the parameter settings for the ExGuards door lock and extraction system

User menu

Menu Access (P) + (2) →	↓		
Damper Open time	dot	[Seconds]	The time the damper must be open before the electronic door lock opens and the damper can return to closed position.
Feedback sensor	FbS	5 = 5k Ω 10 = 10 kΩ	Feedback potentiometer type: either a 10.000 ohms solution or 5.000 ohms solution. Default value is 5
Feedback sensor active (*)	FbA	[0,1,2]	On/Off by the feedback potentiometer. In the Off position there is no monitoring for the alarm codes A10, A11, A12 and A13.
Door Lock open	dLo	[Seconds]	Time until door-opening is possible.
Door alarm	dA	[0, 1]	Turns on the door alarm via the reed-switch. In the Off position there is no monitoring on the door and for the alarm codes A20 and A21.
Door alarm delay	dAd	[Seconds]	Door delay time.
Extraction alarm	EUA	On/Off	If this sensor is active, the surveillance is active for monitoring the extraction via a temperature measurement. Applies to alarm codes A30 and A31.
Extraction extra	EUE	[Seconds]	An additional extraction of the chemical cabinet, in case the door is not closed properly.
Periodic Extraction	PE	[0-24 h]	Number of automatic extractions/flushings of the storage chamber per 24 hours. Factory setting = 4.
Buzzer	bU	On/Off	Buzzer On/Off.

* Explanation of FbA

Value:	Sensor	Explanation of the FbA points
0	Off	Function is deactivated
1	On	Monitoring of damper - no short circuit and cable breakage control
2	On	Monitoring of dampers - with short circuit and cable breakage control

Other shortcuts

Buttons:	Duration:	Function:
(P) + (2)	3 seconds	Access to the user menu and alarm settings.

Error codes - ExGuard

The following table covers the different error codes that might occur for the ExGuard

The extraction system monitors multiple error types. In case of errors, these are shown on the display. In the case of alarms, ensure the door is closed.

Due to user and environmental safety concerns, alarms relating to the extraction system cannot be reset. Additionally the door opening procedure cannot be initiated while these alarm conditions persist.

In case of alarms related to the extraction system please contact Gram BioLine service for further support.

Display code	Explanation
A10	Damper cannot open.
A11	Damper cannot close.
A12	Low resistance - "Short circuit" on circuit.
A13	High resistance - "Cable Break" on circuit.
A20	Door alarm - Door is not closed properly.
A21	Door alarm - Sensor fault on door sensor.
A30	Insufficient air flow registered in extraction system.
A31	Sensor fault in the extraction system.

ExGuard - Opening and closing door

The following part covers how the door opens and closes upon activation of the door lock

Door opening process

When the user needs access to the storage chamber, press ① on the ExGuards front panel.

This starts the extraction process allowing the damper to open, starting the extraction process. Once the extraction is complete, the electromagnetic door lock disengages and allows the door to be opened. Closing the door reengages the electromagnetic lock.



Once the door is closed and electromagnetic door lock has been engaged, the extraction process must be reinitiated to access the storage chamber.

Extraction process in details

Opening the door

When closed, the door is locked - visualised by the red LED to the right of the display.

- ↳ To access the ExGuard cabinet, press ① on the keypad, initiating extraction of the storage chamber.
- ↳ The display will countdown from 100.
- ↳ When the countdown reaches 0, the display will show the code: CL (Clear), and give off a beep. Signifying a successful extraction.
- ↳ The red LED turns off and the three green LEDs on the left turn on (blinking).
- ↳ The door can now be opened, and the door lock is disengaged for 5 seconds!

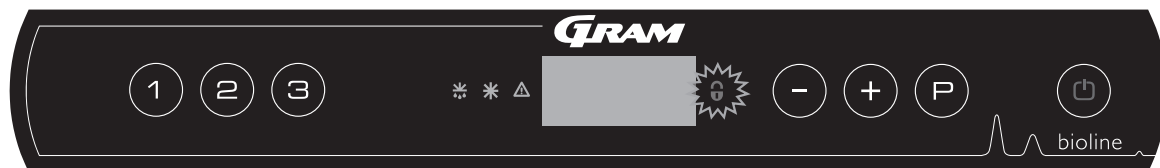

Closing and locking the door

5 seconds after the green LEDs has started to blink the cabinet reengages the door locking mechanism. (depending on parameter "dLo")

- ↳ Close door
- ↳ 2 short beeps indicate that the door locking process has begun.
- ↳ CL disappears from the display, the green LEDs turns off and the red LED turns on.
- ↳ A count from 0 to 100 commences. 100 signifying the damper has moved to the closed position.
- ↳ Upon reaching 100 in the count, the display will change to show LO for 5 seconds.
- ↳ Once the door is closed and electromagnetic door lock has been engaged, the extraction process must be reinitiated to access the storage chamber.



Even if the door is open for a longer time then parameter "dLo" is set for, the door -locking process will start at the set time, meaning that as soon as the door is closed it cannot be re-opened before the extraction process is repeated

Parameter settings

Damper Open time

The following part covers the adjustments of the dampers opening time.

Dot - Adjusting the time for how long the damper is open [seconds]

- ↳ Press and hold **(P)** + **(2)** for more than 3 seconds
- ↳ Dot is now shown in display.
- ↳ Press **(P)** to select "dot". The Damper Open Time is now present in the display.
- ↳ Press **(-)** or **(+)** to set the desired opening time for the damper [Default is 20 seconds].
- ↳ Press **(P)** to confirm the set value.

The time for Damper Open time is now set, proceed to other parameters by pressing **(M)**, and then navigate by using **(-)** or **(+)**

- ↳ Leave the user menu by pressing **(M)** several times until the display goes back to blank.



WARNING!

All settings must be based on the intended use and based on EN 60079-10, in order to achieve the correct use and safety for the user and the environment.

Feedback sensor

The following parts covers setting the feedback sensor for the extraction system.

Feedback sensor activation

The following parts covers setting the feedback sensor for the extraction system.

FbS – Setting the feedback potentiometer type for the sensor

- ↳ Press and hold **(P)** + **(2)** for more than 3 seconds
- ↳ Press **(-)** to proceed to “FbS”
- ↳ Press **(P)** to select “FbS”. Feedback sensor is now shown in the display.
- ↳ Press **(-)** or **(+)** to set the sensor feedback [5 = 5k Ω / 10 = 10k Ω; Default value is 5]
- ↳ Press **(P)** to confirm the set value.

The feedback sensor is now configured, proceed to other parameters by pressing **(M)**, and then navigate by using **(-)** or **(+)**.

- ↳ Leave the user menu by pressing **(M)** several times until the display goes back to blank.

FbA – Activation / Deactivation and value setting for the feedback sensor

- ↳ Press and hold **(P)** + **(2)** for more than 3 seconds
- ↳ Press **(-)** to proceed to “FbA”
- ↳ Press **(P)** to select “FbA”. Feedback sensor active is now shown in the display.
- ↳ Press **(-)** or **(+)** to set the sensor value * [1-2 = activated / 0 = deactivated; Default value is 1]
- ↳ Press **(P)** to confirm the set value.

The feedback sensor is now configured, proceed to other parameters by pressing **(M)**, and then navigate by using **(-)** or **(+)**.

- ↳ Leave the user menu by pressing **(M)** several times until the display goes back to blank.

* Values for feedback sensor:

Value:	Sensor	Explanation of the FbA points
0	Off	Function is deactivated
1	On	Monitoring of damper with no short circuit and cable breakage control
2	On	Monitoring of dampers and with short circuit and cable breakage control



WARNING!

All settings must be based on the intended use and based on EN 60079-10, in order to achieve the correct use and safety for the user and the environment.

Door Lock open time

The following part covers the timing and setting of the door lock and alarm.

Door alarm activation

The following part covers the timing and setting of the door lock and alarm.

dLo – Adjusting how long the door lock is open [seconds]

- ↳ Press and hold (P) + (2) or more than 3 seconds
- ↳ Press (-) to proceed to "dLo"
- ↳ Press (P) to select "dLo". Door Lock open is now shown in the display.
- ↳ Press (-) or (+) to set the time the door lock must be open in increments of +/-1 seconds [Default value is 5 seconds]
- ↳ Press (P) to confirm the set value.

The time the door lock must be open is now set, proceed to other parameters by pressing (⏏), and then navigate by using (-) or (+).

- ↳ Leave the user menu by pressing (⏏) several times until the display goes back to blank.

dA – Activation / Deactivation of the door alarm

- ↳ Press and hold (P) + (2) for more than 3 seconds
- ↳ Press (-) to proceed to "dA"
- ↳ Press (P) to select "dA". Door alarm is now present in the display.
- ↳ Press (-) or (+) to activate/deactivate the alarm [1 = activated / 0 = deactivated; Default value is 1]
- ↳ Press (P) to confirm the set value.

The door alarm is now configured, proceed to other parameters by pressing (⏏), and then navigate by using (-) or (+).

- ↳ Leave the user menu by pressing (⏏) several times until the display goes back to blank.



WARNING!

All settings must be based on the intended use and based on EN 60079-10, in order to achieve the correct use and safety for the user and the environment.

Door alarm delay

The following part covers the timing and setting of the door locks alarm delay.

dAd – Adjusting the delay of the door alarm [seconds]

- ↳ Press and hold P + 2 for more than 3 seconds
- ↳ Press - to proceed to “dAd”
- ↳ Press P to select “dAd”. Door alarm delay is now shown in the display.
- ↳ Press - or + to set the desired delay for the door alarm in increments of +/-5 seconds [Default value is 60 seconds]
- ↳ Press P to confirm the set value.

The door alarm delay is now set, proceed to other parameters by pressing E , and then navigate by using - or + .

- ↳ Leave the user menu by pressing E several times until the display goes back to blank.



WARNING!

All settings must be based on the intended use and based on EN 60079-10, in order to achieve the correct use and safety for the user and the environment.

Extraction alarm

The following parts covers the setting of the extraction malfunction alarm for the extraction system.

Only applies if sensor is present

EUA – Activation / Deactivation of the extraction alarm (if present)

If this sensor is active, the surveillance is active for monitoring the extraction malfunction via a temperature measurement. Applies to alarm codes A30 and A31.

- ↳ Press and hold P + 2 for more than 3 seconds
- ↳ Press - to proceed to "EUA"
- ↳ Press P to select "EUA". Extraction alarm is now shown in the display.
- ↳ Press - or + to activate/deactivate the alarm [1 = activated / 0 = deactivated; Default value is 1 if the sensor is present, otherwise it is 0]
- ↳ Press P to confirm the set value.

The extraction alarm is now configured, proceed to other parameters by pressing ⏏ , and then navigate by using - or + .

- ↳ Leave the user menu by pressing ⏏ several times until the display goes back to blank.

Extraction extra

The following parts covers the adjustment of the extraction timing for the extraction system.

Periodic extraction frequency

The following parts covers the adjustment of the extraction timing for the extraction system.

EUE – Adjusting the extra extraction time [seconds]

- ↳ Press and hold **(P)** + **(2)** for more than 3 seconds
- ↳ Press **(-)** to proceed to “EUE”
- ↳ Press **(P)** to select “EUE”. Extraction extra is now shown in the display.
- ↳ Press **(-)** or **(+)** to set the desired extra extraction time in increments of +/-5 seconds [Default value is 120 seconds]
- ↳ Press **(P)** to confirm the set value.

The extra extraction time is now set, proceed to other parameters by pressing **(⏏)**, and then navigate by using **(-)** or **(+)**.

- ↳ Leave the user menu by pressing **(⏏)** several times until the display goes back to blank.



Extra extraction happens when the electromagnet for the door locking system senses that the door is not properly closed and locked. The door locking circuit is a separate system from the door alarm in the cooling system.

PE – Setting up the periodic extraction frequency

- ↳ Press and hold **(P)** + **(2)** for more than 3 seconds
- ↳ Press **(-)** to proceed to “PE”
- ↳ Press **(P)** to select “PE”. Periodic Extraction is now shown in the display.
- ↳ Press **(-)** or **(+)** to set the desired periodic extraction frequency pr. 24 hours. [Default value is 4 pr. 24 hours].
- ↳ Press **(P)** to confirm the set value.

The periodic extraction frequency is now set, proceed to other parameters by pressing **(⏏)**, and then navigate by using **(-)** or **(+)**.

- ↳ Leave the user menu by pressing **(⏏)** several times until the display goes back to blank.

Buzzer

The following part covers setting the alarm buzzer On/Off

bU – Activation / Deactivation of the alarm buzzer

- ↳ Press and hold (P) + (2) for more than 3 seconds
- ↳ Press (-) to proceed to "bU"
- ↳ Press (P) to select "bU". Buzzer On/Off is now shown in the display.
- ↳ Press (-) or (+) to activate/deactivate the buzzer [1 = activated / 0 = deactivated; Default value is 1]
- ↳ Press (P) to confirm the set value.

The buzzer is now configured, proceed to other parameters by pressing (⏪), and then navigate by using (-) or (+).

- ↳ Leave the user menu by pressing (⏩) several times until the display goes back to blank.

Ordinary use



The following part shows how items should be placed and stored in the cabinet.

Keep the marked areas in the cabinet (shown on this page) clear of all items, thereby ensuring adequate air circulation, and therein cooling.

Do not place items beneath the lowest shelf bracket.

All products to be stored, that are not wrapped or packed, must be covered in order to avoid unnecessary corrosion of the inner parts of the cabinet.



Items placed on the bottom of the cabinet will cause the air circulation to be impeded, which reduces the cabinets performance.

The items should be evenly distributed in the cabinet, with minimum layer-thickness / maximum surface. And at the same time, the air should be able to circulate freely between the items.

The illustration on the right shows the maximum load height of the cabinet.

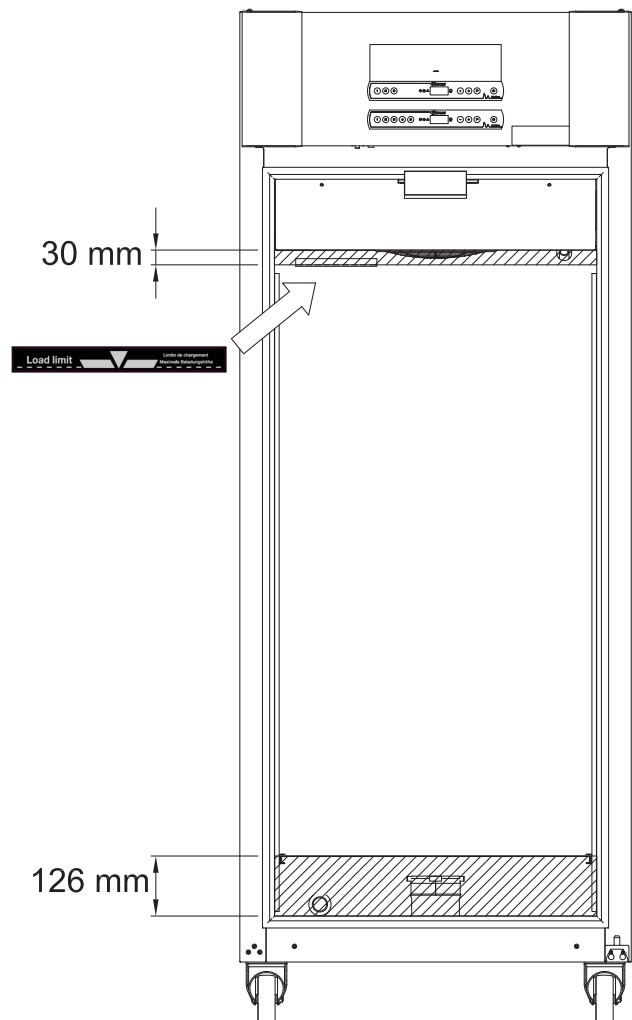

IMPORTANT!

Be aware not to block the extraction ducting in the top and bottom of the cabinet, as this will have serious effects on the cabinets ability to extract the atmospheres from the cabinet during the extraction process, before opening the door (see section "Opening and closing of door"). Items must not come into close proximity to the extraction ducting

Regular maintenance

Cleaning

Inadequate cleaning can lead to the cabinet not functioning properly or at all.



Always disconnect the cabinet before cleaning.

The cabinet should be cleaned internally with a mild soap solution (max. 85° C) at suitable intervals and checked thoroughly before it is put into operation again.

Ensure that there is not ingress of contaminants in the damper valves in the extraction ducting which will impede their function.

The compressor compartment and in particular the condenser must be kept free from dust and dirt. This is best done with a vacuum cleaner and a brush.

The air filters on the condenser and the front panel should be removed and cleaned with warm water (max. 50° C).

The re-evaporation tray should be emptied and cleaned at least once a year.

Do not flush compressor compartment and evaporator with water as this may cause short-circuits in the electrical system.

Cleansing agents containing chlorine or compounds of chlorine as well as other corrosive agents, may not be used, as they might cause corrosion to the stainless panels of the cabinet and the evaporator system.

The location of the condensers for top-mounted compressors is illustrated below.

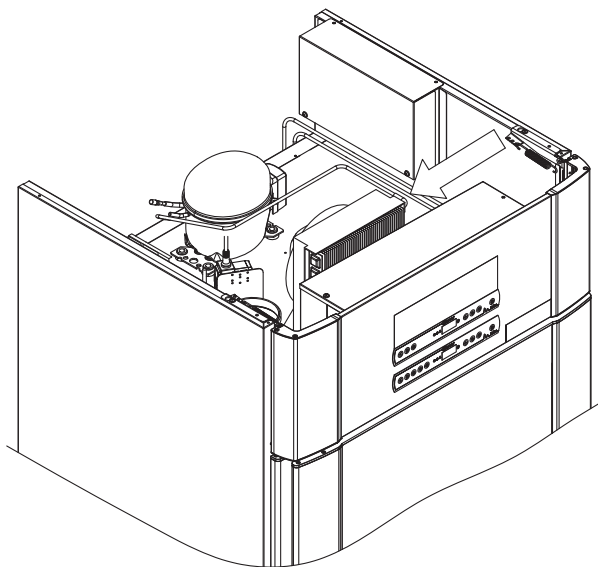

Door gasket

The following part covers the importance of a properly functioning door gasket.

Door gaskets are an important part of a cabinet. Impaired door gaskets can lead to increased humidity, iced up evaporator (and thus reduced cooling capacity), and in some cases, decreased longevity of the cabinet.

It is therefore very important to be aware of the door gaskets condition. Regular inspection is recommended.

The door gasket should be cleaned regularly with a mild soap solution.

If a gasket is to be replaced, please contact your local Gram BioLine distributor.

The illustration below shows location of the door gasket.

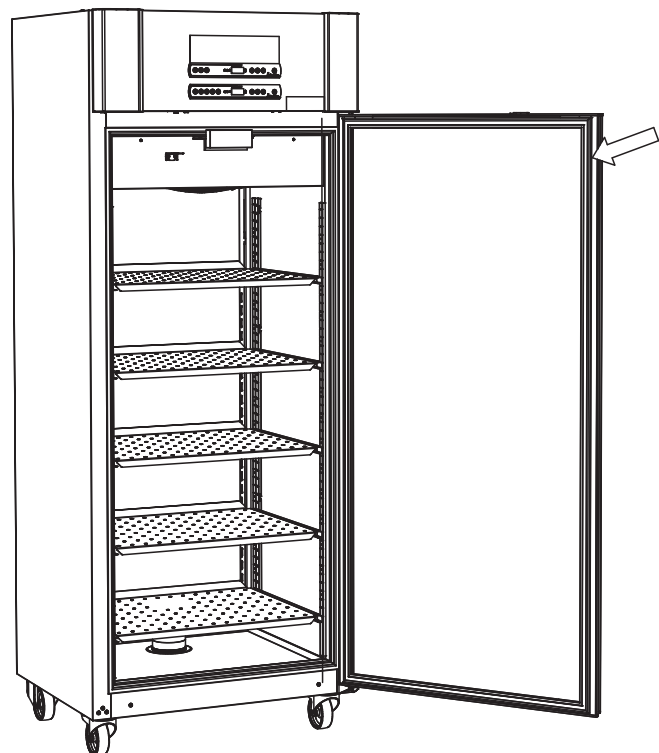

General info



Responsibility

Read the following carefully, for information on technical safety and responsibility on Gram BioLine products.



Is the cabinet being used for purposes other than its intended use or use of the cabinet is not in accordance with guidelines specified in the instructions for use, the user bears full responsibility for any consequences thereof.



Defective parts must be replaced with original parts from Gram BioLine. Gram BioLine can only guarantee functional and safety requirements on the cabinets, if above mentioned is adhered to.



The cabinets refrigeration components should at least once a year, be checked by Gram BioLine technician or a similar authorised professional.



The cabinet has to be disconnected at the mains if service is to be done on electrical components of the cabinet.

It is not sufficient to switch the cabinet Off on the front panel, due to the fact that there is still a possibility that there is current in some of the components of the cabinet.



Contact Gram BioLine customer service or qualified personnel if the light bulb(s) in the two spots above the door needs replacing.

Service

The refrigerating system and the hermetically sealed compressor require no maintenance. However, the condenser and air filter requires regular cleaning.

If refrigeration falls, first look to see whether the cabinet has been unintentionally switched Off, or whether a fuse has blown.

If the cause of failure cannot be found, contact your supplier quoting TYPE, PART NO and SE. NO of the cabinet. This information can be found on the nameplate.

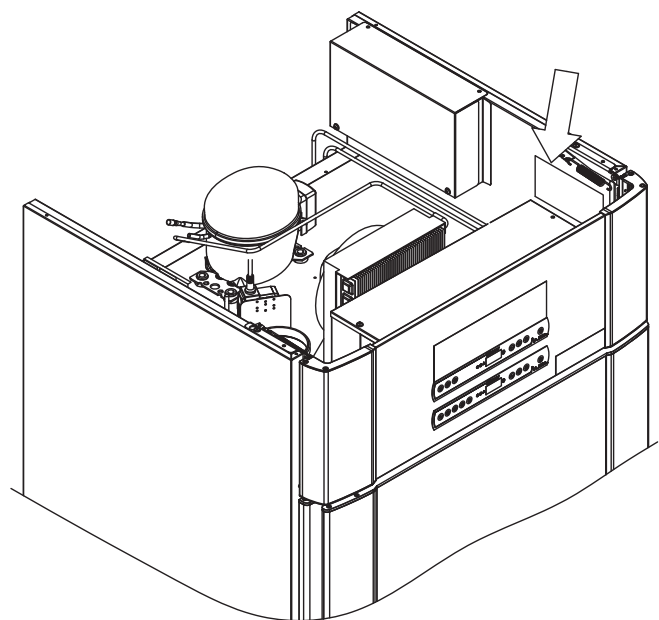

Defrost water

The cabinet creates defrost water, that is directed out into a re-evaporation tray at the back of the cabinet.

Defrost water is led through a tube in insulation to a re-evaporation tray at the back of the cabinet.



It is recommended that the re-evaporation tray is cleaned at least once a year. This shall only be done while the cabinet is turned Off.

Be careful not to damage the defrost water tube and heating element (located in the tray) when cleaning.

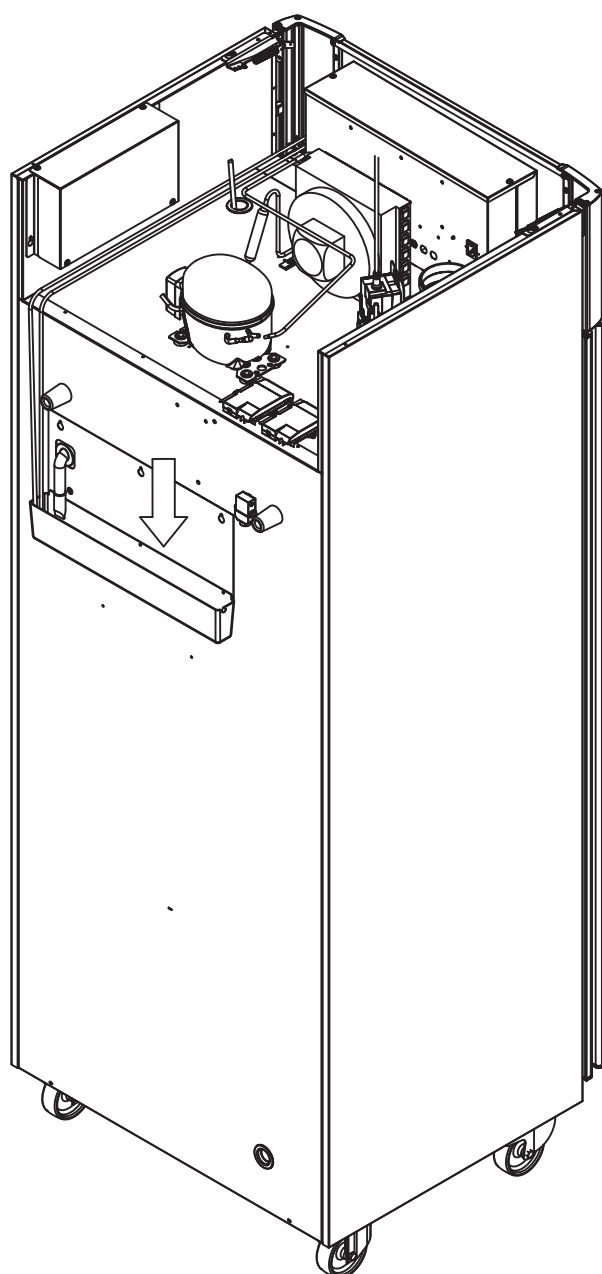

Door closing mechanism

Please note that ExGuard cabinets are equipped with doors that have a self-closing mechanism.

The door is equipped with an automatic closing mechanism. Open the door up to 90°, and it will shut by itself. Open the door more than 90° and door will remain open.



See section "Opening and closing of door" for further details regarding opening and closing of door.

Access port

All BioLine cabinets are equipped with an access port on the back of the cabinets, this can be used to easily fit external sensors and the like.

The illustration below shows the access port in the ExGuard 600W cabinet.

All access ports are constructed in the same fashion, with a conical polystyrene plug (fitted from the back of the cabinet) and a plastic cap (fitted from the inside of the cabinet).



Please note, it is very important to re-fit the polystyrene plug (position 1) and plastic cap (position 2) after mounting sensor, probe etc. failing to do so can result in lowered performance or break-down of the cabinet. Due to the intended use of the ExGuard cabinet, it is critical to ensure a proper seal in the access port so not to draw in false air.

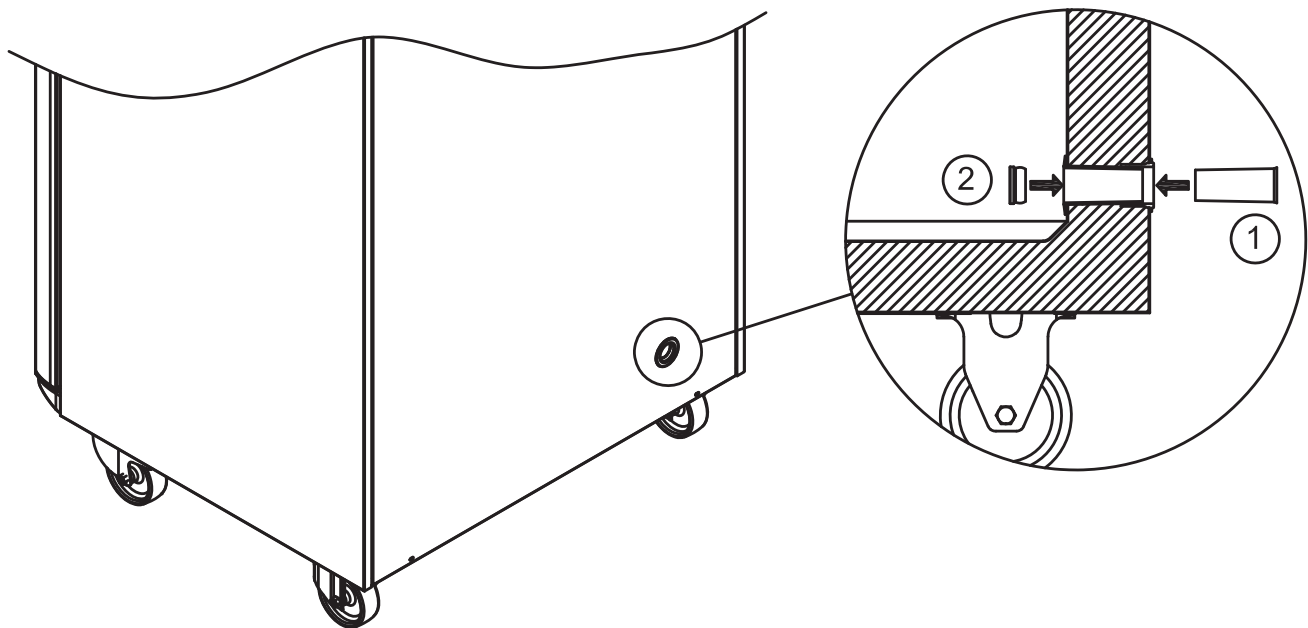

Important

*In the event of need for product support.
Do not hesitate to contact us at:*
support@gram-bioline.com



IMPORTANT!

1. There may be sharp edges on the cabinet housing, compressor room, and interior. Show due diligence when handling the cabinet, neglect of these precautions can lead to injuries.
2. Danger of wedging of body parts in the frame slot between the door and the cabinet, show due diligence when opening and closing the cabinet door. Negligence of these precautions can lead to injuries.
3. Danger of wedging of body parts in the drawer column between the drawers and interior of the cabinet, show due diligence when using the drawers. Negligence of these precautions can lead to injuries.
4. Be aware the cabinet door is locked magnetically and can only be opened by performing the extraction process. If for any reason a failure or error should occur during this process, **do not attempt repair or remedy the fault, contact Gram BioLine technical support.**
5. Be particularly vigilant in relation to closing doors with self-close mechanism as these are spring-loaded. Negligence of these precautions can lead to injuries.
6. Unlocked castors can lead to unexpected movements of the cabinet. Lock the castors after installation. Negligence of these precautions can lead to injuries.
7. The re-evaporation tray, re-evaporation tray heating element, pressure pipes and compressors develops considerable heat during operation. Assure yourself that these components are sufficiently tempered before touching. Negligence of these precautions can lead to injuries.
8. The evaporator develops considerable cold during operation. Reassure yourself that the evaporator is sufficiently tempered before touching. Negligence of this precaution may lead to injuries.
9. The fan may cause injury during operation, avoiding touching the fans while the cabinet is connected to the mains. Negligence of these precautions can lead to injuries.
10. Make sure the ventilation system properly installed to the cabinets extraction ducts and are working as intended in order to prevent hazardous or dangerous situations.
11. No unauthorized modification allowed.

Disposal

Electrical and electronic equipment (EEE) contains materials, components and substances that can be dangerous and harmful to human health and the environment if the waste (WEEE) is not disposed of properly.

Products that are labelled with a “crossed-out wheelie bin” is electric and electronic equipment. The crossed out wheelie bin symbolizes that waste of this type can not be disposed of with unsorted municipal waste, but must be collected separately.

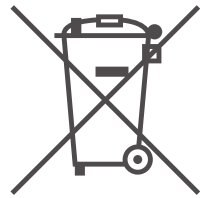

Contact you local BioLine distributor when the cabinet needs to be disposed of.

For additional information, see our website:
www.gram-bioline.com

Datasheet

General data:

ExGuard ER 600 G

Technical specifications	Data
Ambient temperature range	Solid door +10/+43°C; glass door +10/+38°C
Temperature range	-2 °C / +20 °C
Connection	230 VAC / 50 Hz
Control Unit	2 x Gram BioLine MPC-46
SW variant (ER model)	M5+
SW variant (Extraction)	C1
Alarms	Acoustic and visual temperature and door alarms
Alarm ports	Voltage free contact (230 VAC/8A)
Access port	1 pcs. Ø24 mm
Gross volume	614 litres
Net volume	486 litres
Door	Right or left hinged, either solid or glass door
Material interior	Stainless steel 4016
Materiale exterior	White lacquered steel or stainless steel 4016
Wall thickness	70 mm
Door thickness	80 mm
Insulation	Polyurethane foam
Dimensions: H x B x D	1996/2246 x 820 x 785 mm
Air system	Gram BioLine ventilated air distribution system
Defrost system	Automatic smart defrost with re-evaporation of the defrost water. Heating element
IP class	IP21
Ventilation connection	100 mm spiral ducting
Ventilation requirements	144 m ³ /h air flow per cabinet

ExGuard ER 600 G Solid door

Technical specifications	Data
K-Value	0,2685 W/(m ² *K)
ATEX certifikate	DTI 19ATEX0113X
ATEX Marking	II 3G Ex ec nC ic IIB T1 Gc
Refrigerant	R290
Refrigerant charge	90 g
Refrigeration capacity at -10°C	389 W
GWP – CO ₂ e	-
Energy consumption	1,665 kWh/24h
Heat emission 100%	314,13 W
Heat emission default setpoint	67,3 W
Nominel consumption	316,3 W / 1,95 A
Start current	9,7 A
Gross weight	181kg
Net weight*	166kg
Sound level	46,3 dB(A)

ExGuard ER 600 G Glass door

Technical specifications	Data
K-Value	0,453 W/(m ² *K)
ATEX certifikate	DTI 19ATEX0113X
ATEX Marking	II 3G Ex ec nC ic IIB T1 Gc
Refrigerant	R290
Refrigerant charge	90 g
Refrigeration capacity at -10°C	389 W
GWP – CO ₂ e	-
Energy consumption	2,08 kWh/24h
Heat emission 100 %	319,5 W
Heat emission default setpoint	87,0 W
Nominel consumption	316,3 W / 1,95 A
Start current	9,7 A
Gross weight	181 kg
Net weight*	166 kg
Sound level	45,3 dB(A)

Declaration of conformity

Declaration of conformity



English EC Declaration of Conformity

We, **Gram Commercial** declare under sole responsibility that the following products:

Range:	ExGuard
Model:	ER600W
Refrigerant:	R134a or R290
Product description:	Refrigerators for storing harmful or odorous chemicals with built in extraction system
Serial number (Week/year):	24/2020 onwards

To which this declaration relates, is in compliance with all the applicable essential requirements, and other provisions of the European Council Directive and regulations.

Directives and Regulations of the European Parliament and of the Council:

- ATEX Directive 2014/34/EU
- Pressure Equipment Directive 2014/68/EU
- Directive for Machinery 2006/42/EU
- Low Voltage Directive 2014/35/EU
- EMC Directive 2014/30/EU
- RoHS 2011/65/EU
- REACH (EU) nr. 1907/2006
- Fluorinated greenhouse gases (EU) nr. 517/2014

Product compliance has been demonstrated on the basis of:

Harmonized Standards:	Text:
DS/EN 61010-1:2010	Safety requirements for electrical equipment for measurement, control, and laboratory use - Part 1: General requirements
DS/EN 61326-1: 2013	Electrical equipment for measurement, control and laboratory use – EMC requirements – Part 1: General requirements
DS/EN IEC 61000-3-2:2019	Electromagnetic compatibility (EMC) – Part 3-2: Limits – Limits for harmonic current emissions (equipment input current ≤16 A per phase)
DS/EN 61000-3-3:2013	Electromagnetic compatibility (EMC) – Part 3-3: Limits – Limitation of voltage changes, voltage fluctuations and flicker in public low-voltage supply systems, for equipment with rated current ≤= 16 A per phase and not subject to conditional connection
DS/EN IEC 60079-0:2018 DS/EN IEC 60079-0:2018/AC:2020	Explosive atmospheres – Part 0: Equipment – General requirements
DS/EN 60079-7:2015 DS/EN 60079-7:2015/A1:2018	Explosive atmospheres – Part 7: Equipment protection by increased safety 'e'
DS/EN 60079-11:2012	Explosive atmospheres – Part 11: Equipment protection by intrinsic safety 'i'
DS/EN IEC 60079-15:2019	Explosive atmospheres – Part 15: Equipment protection by type of protection 'n'
DS/EN ISO 3744:2010	Acoustics – Determination of sound power levels and sound energy levels of noise sources using sound pressure – Engineering methods for an essentially free field over a reflecting plane
DS/EN ISO 9001:2015	Quality management systems – Requirements
DS/EN ISO 14001:2015	Environmental management systems – Requirements with guidance for use

Gram Commercial
 Aage Grams Vej 1
 DK-6500 Vojens
 Telephone: + 45 73 20 13 00

Vojens, 30.09.2020

John B. S. Petersen
 Approval Manager

Rev. 005 – 30.09.2020

General info

Piping diagram

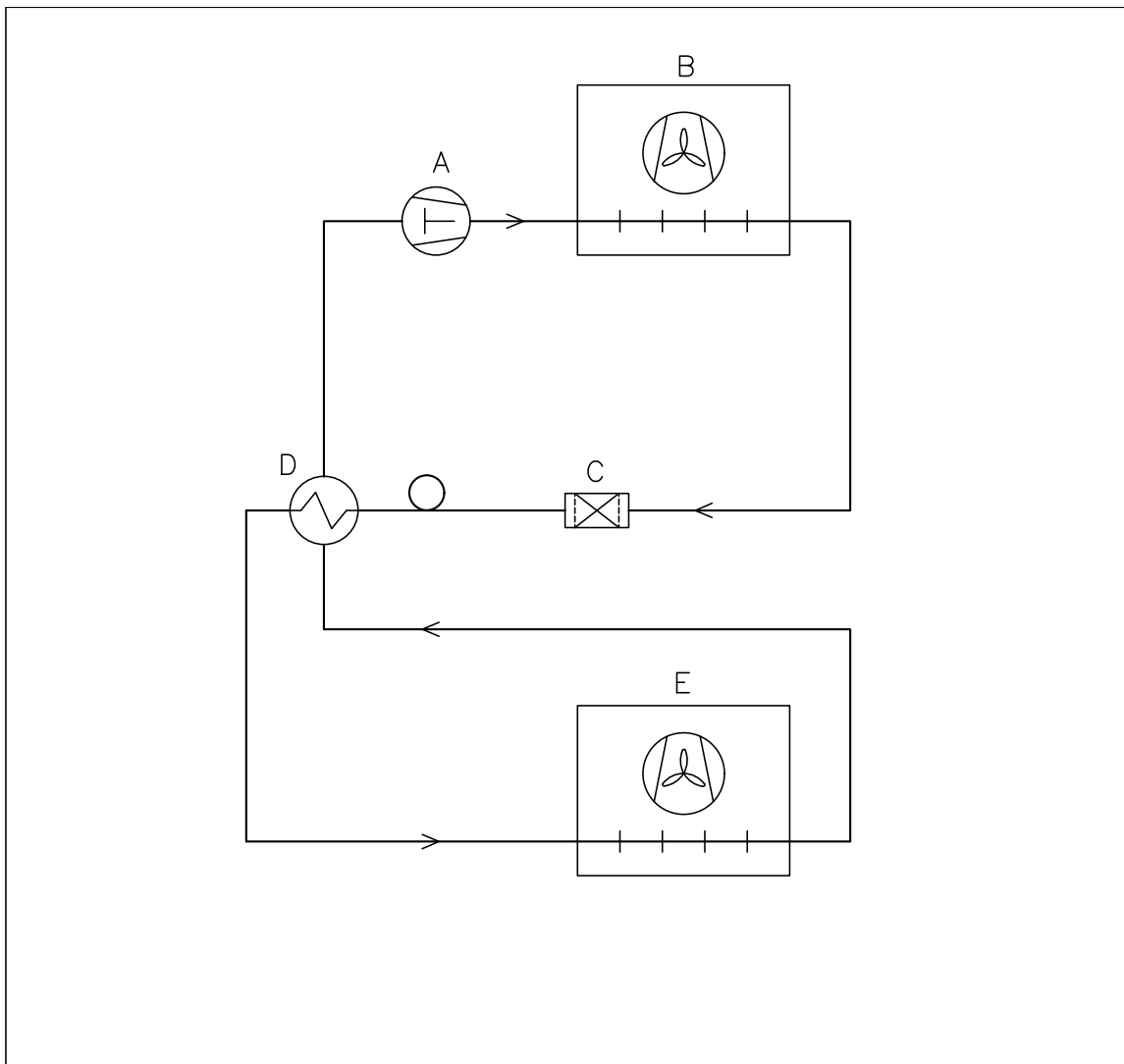

	DK	GB	D			
A	Kompressor	Compressor	Kompressor			
B	Kondensator	Condenser	Verflüssiger			
C	Tørrefilter	Filter drier	Trockenfilter			
D	Varmeudveksler	Heat exchanger	Wärmeaustauscher			
E	Fordamper	Evaporator	Verdampfer			
Revision			Inspection / important Dimension marked with			
Description. Piping diagram ExGuard ER600W			(X.XX)			
			General tolerance: ISO 2768-m : ISO 286-2			
Gram Commercial (CVR-nr. 41423986) Aage Grams Vej 1 6500 Vojens	Date	Sign.	Sheetsize	Drawing no.	Sheet no.	Rev.
	04-09-2020	JABP	4			
All rights to this drawing belongs to Gram Commercial A/S, cf. law of Copyright. Thus the drawing should notwithout our written permission be copied, presented or passed over to a third person. Misuse will lead to prosecution.						

General info

bioline

Wiring diagram

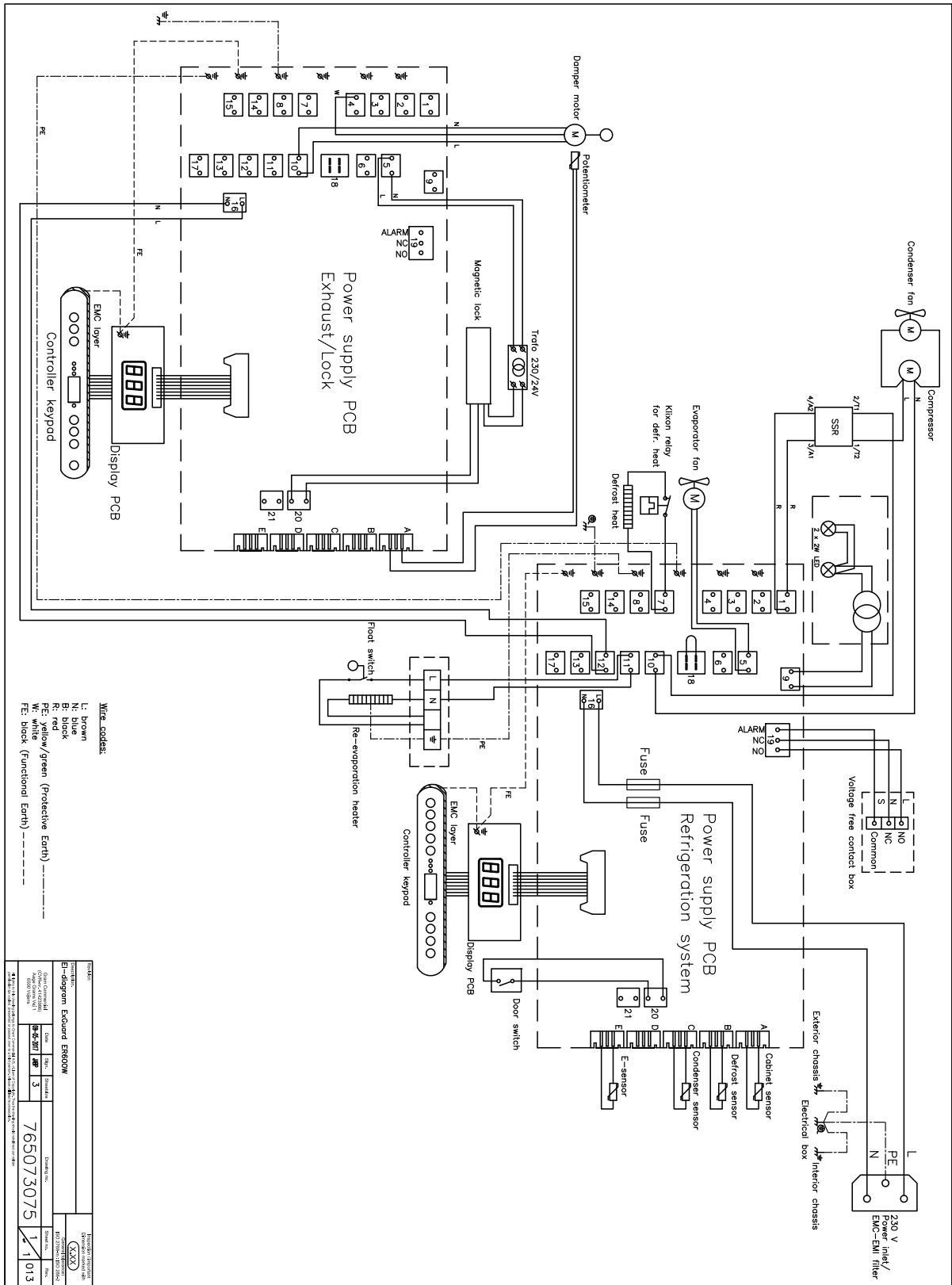



Gram Commercial

Aage Grams Vej 1 · 6500 Vojens · Danmark

Tel: +45 73 20 13 00 · Fax: +45 73 20 13 01

e-mail: info@gram-bioline.com

www.gram-bioline.com

Gram Commercial, filial af Hoshizaki Europe BV, Holland



Biostorage you can depend on